

Higher Electricity  
Past Paper Questions  
Book 1

## Contents

Band Theory and Conductivity	pg 2-16
Practical Circuits	pg 17-25
Capacitance	pg 26-52

## Band Theory and Conductivity

1. Materials are "doped" to produce n-type semiconductor material.

In n-type semiconductor material

- A the majority charge carriers are electrons
- B the majority charge carriers are neutrons
- C the majority charge carriers are protons
- D there are always more protons than neutrons
- E there are always more electrons than protons.

2. In the following circuit, the component X is used to drive a motor.

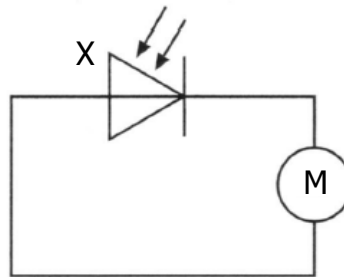

Which of the following gives the name of component X and its mode of operation?

	<i>Name of component X</i>	<i>Mode of operation</i>
A	light-emitting diode	photoconductive
B	light-emitting diode	photovoltaic
C	photodiode	photoconductive
D	photodiode	photovoltaic
E	solar cell	photoconductive

3. The letters **X**, **Y** and **Z** represent three missing words from the following passage.

*Materials can be divided into three broad categories according to their electrical resistance.*

*.....**X**..... have a very high resistance.*

*.....**Y**..... have a high resistance in their pure form but when small amounts of certain impurities are added, the resistance decreases.*

*.....**Z**..... have a low resistance.*

Which row in the table shows the missing words?

	<b>X</b>	<b>Y</b>	<b>Z</b>
A	conductors	insulators	semi-conductors
B	semi-conductors	insulators	conductors
C	insulators	semi-conductors	conductors
D	conductors	semi-conductors	insulators
E	insulators	conductors	semi-conductors

4. A p-n junction diode is forward biased.  
Positive and negative charge carriers recombine in the junction region.  
This causes the emission of
- A a hole
  - B an electron
  - C an electron-hole pair
  - D a proton
  - E a photon

5. A student writes the following statements about p-type semiconductor material.

- I Most charge carriers are positive.
- II The p-type material has a positive charge.
- III Impurity atoms in the material have 3 outer electrons.

Which of these statements is/are true?

- A I only
- B II only
- C I and II only
- D I and III only
- E I, II and III

6. An LED is connected as shown.

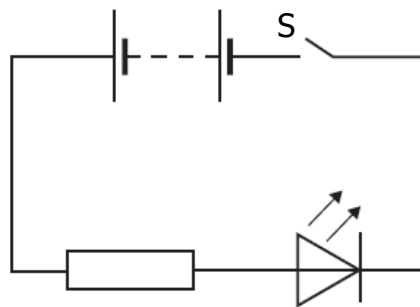

When switch S is closed

- A the p-n junction is reverse biased and free charge carriers are produced which may recombine to give quanta of radiation
- B the p-n junction is forward biased and positive and negative charge carriers are produced by the action of light
- C the p-n junction is reverse biased and positive and negative charge carriers are produced by the action of light
- D the p-n junction is forward biased and positive and negative charge carriers may recombine to give quanta of radiation
- E the p-n junction is reverse biased and positive and negative charge carriers may recombine to give quanta of radiation.

7. The letters **X**, **Y** and **Z** represent missing words in the following passage.

*Solids can be categorised as conductors, semiconductors or insulators.*

*In.....**X**..... the energy gap between the valence band and the conduction band is .....**Y**..... allowing .....**Z**..... conduction to take place at room temperature.*

Which row in the table shows the missing words?

	<b>X</b>	<b>Y</b>	<b>Z</b>
A	conductors	large	no
B	semi-conductors	small	no
C	conductors	large	some
D	semi-conductors	small	some
E	insulators	small	no

8. A crystal of silicon is "doped" with arsenic. This means that a small number of the silicon atoms are replaced with arsenic atoms.

The effect of the doping on the crystal is to

- A make it into a photodiode
- B make it into an insulator
- C increase its resistance
- D decrease its resistance
- E allow it to conduct in only one direction.

9. A student reads the following passage in a physics dictionary.
- "... is a solid state device in which positive and negative charge carriers are produced by the action of light on a p-n junction."*
- The passage describes
- A a thermistor
  - B a MOSFET
  - C a photodiode
  - D a laser
  - E an LED.

10. A student makes the following statements about p-n junction devices.
- I In solar cells, a potential difference is produced when photons are incident on the junction.
  - II The photovoltaic effect occurs in solar cells.
  - III in LEDs, photons are emitted from the junction when a current is passed through it.
- Which of these statements is/are correct?
- A I only
  - B III only
  - C I and II only
  - D I and III only
  - E I, II and III

11. The letters **X**, **Y** and **Z** represent three missing words from the following passage.

*Solids can be divided into 3 broad categories: conductors, insulators and semiconductors.*

*In.....**X**.....the conduction band is not completely full and this allows electrons to move easily.*

*In.....**Y**.....the valence band is full.*

*In.....**Z**.....electrons can move from the valence to the conduction band at room temperature.*

Which row in the table shows the missing words?

	<b>X</b>	<b>Y</b>	<b>Z</b>
A	conductors	insulators	semi-conductors
B	semi-conductors	insulators	conductors
C	insulators	semi-conductors	conductors
D	conductors	semi-conductors	insulators
E	insulators	conductors	semi-conductors

12. A sample of pure semiconductor can be doped to form an n-type semiconductor.

Which row in the table describes the majority charge carriers in the n-type semiconductor and how the resistance of the n-type semiconductor compares with that of the pure semiconductor.

	<i>Majority charge carriers</i>	<i>Resistance of n-type semiconductor compared to resistance of pure semiconductor</i>
A	negative	greater
B	positive	greater
C	negative	less
D	positive	less
E	negative	unchanged



13. A student makes the following statements about energy bands in different materials.

- I In metals the highest occupied band is not completely full.
- II In insulators the highest occupied energy band is full.
- III The gap between the valence band and conduction band is smaller in semiconductors than in insulators.

Which of these statements is/are correct?

- A I only
- B II only
- C I and II only
- D I and III only
- E I, II and III

14. A student makes the following statements about conductors, insulators and semiconductors.

- I In conductors, the conduction band is completely filled with electrons.
- II In insulators, the gap between the valence band and the conduction band is large.
- III In semiconductors, increasing the temperature increases the conductivity.

Which of these statements is/are correct?

- A I only
- B II only
- C III only
- D I and II only
- E II and III only

Band Theory and Conductivity; Interference and Diffraction Gratings

15. (a) A sample of pure semiconducting material is doped by adding impurity atoms.

State how adding impurities affects the resistance of the semiconducting material.

1

- (b) The circuit below shows a p-n junction diode used as a light emitting diode (LED).

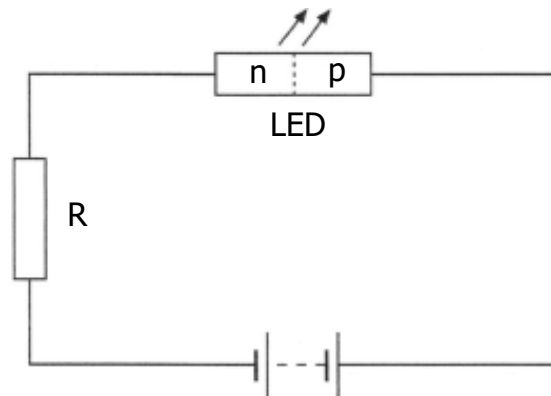

- (i) Explain in terms of the charge carriers how the LED emits light.
- (ii) Monochromatic light from the LED is incident on a grating as shown. The spacing between lines in the grating is  $5.0 \times 10^{-6}$  m.

2

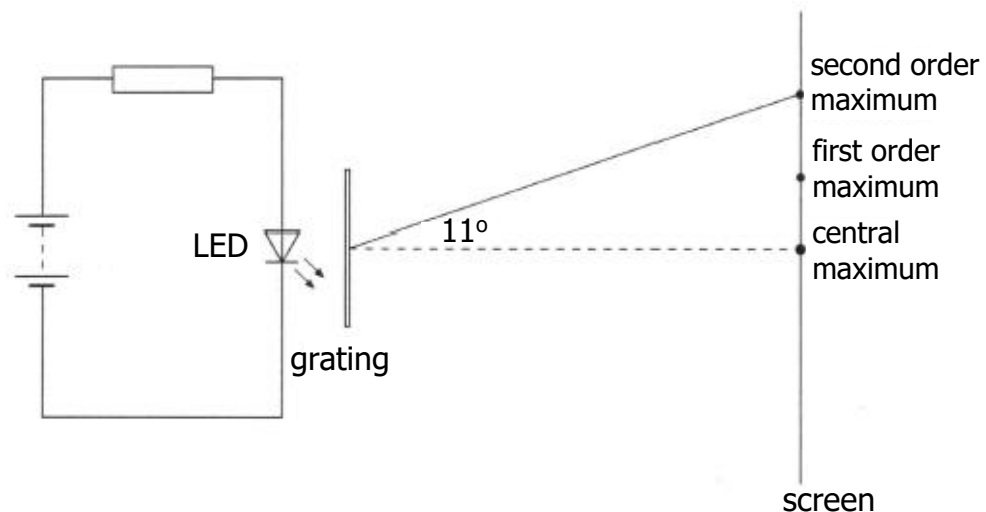

Calculate the wavelength of the light emitted by the LED.

3

Band Theory and Conductivity

16. An LED consists of a p-n junction as shown.

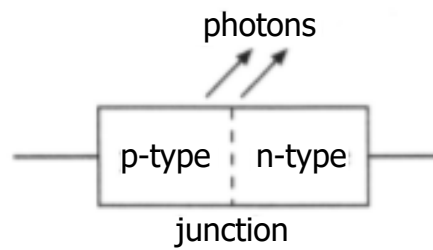

- (a) Copy the diagram and add a battery so that the p-n junction is forward-biased. 1
- (b) Using the terms *electrons*, *holes* and *photons*, explain how light is produced at the p-n junction of the LED. 2
- (c) The LED emits photons of energy  $3.68 \times 10^{-19}$  J.
- (i) Calculate the wavelength of a photon of light from this LED. 4
- (ii) Calculate the minimum potential difference across the p-n junction when it emits photons. 3

Band Theory + Conductivity; Photoelectric Effect; Interference + Diffraction Gratings

17. (a) Light of frequency  $6.7 \times 10^{14}$  Hz is produced at the junction of a light emitting diode (LED).

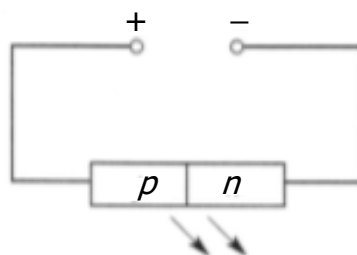

- (i) Describe how the movement of charges in a forward-biased LED produces light. Your description should include the terms: *electrons* ; *holes* ; *photons* and *junction* . 2
- (ii) (A) Calculate the wavelength of the light emitted. 3  
 (B) Use information from the data sheet to determine the colour of this light. 1
- (iii) The table below gives the values of the work function for three metals.

<i>Metal</i>	<i>Work Function (J)</i>
caesium	$3.4 \times 10^{-19}$
strontium	$4.1 \times 10^{-19}$
magnesium	$5.9 \times 10^{-19}$

Light from the LED is now incident on these metals.

Show by calculation which of these metals, if any, release photoelectrons with the light. 4

- (b) Light from a different LED is passed through a grating as shown below.

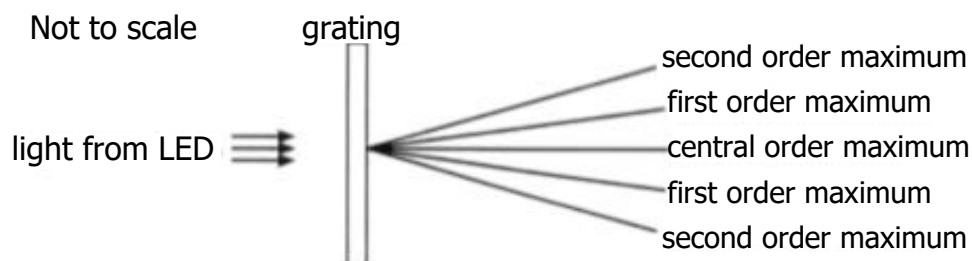

Light from this LED has a wavelength of  $6.35 \times 10^{-7}$  m. The spacing between the lines in the grating is  $5.0 \times 10^{-6}$  m.

Calculate the angle between the central maximum and the **second** order maximum. 3

Band Theory and Conductivity; Irradiance

18. (a) An n-type semiconductor is formed by adding impurity atoms to a sample of pure semiconductor material.

State the effect that the addition of the impurity atoms has on the resistance of the material.

1

- (b) A p-n junction is used as a photodiode as shown.

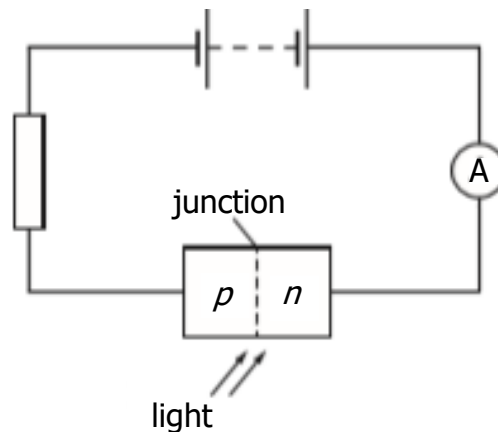

- (i) State the mode in which the photodiode is operating.

1

- (ii) The irradiance of the light on the junction of the photodiode is now increased.

Explain why the current increases in this circuit.

2

- (c) The photodiode is placed at a distance of 1.2 m from a small lamp. The reading on the ammeter is  $3.0 \mu\text{A}$ .

The photodiode is now moved to a distance of 0.80 m from the same lamp.

Assuming that the irradiance of the light on the junction of the photodiode is directly proportional to the current in the circuit, calculate the new reading on the ammeter.

3

## Band Theory and Conductivity

19. (a) Use band theory to explain how electrical conduction takes place in a pure semiconductor such as silicon.

Your explanation should include the terms: *electrons*, *valence band* and *conduction band*.

2

- (b) A light emitting diode (LED) is a p-n junction which emits light.

The table below gives the colour of some LEDs and the voltage across the junction required to switch on the LED.

<i>Colour of LED</i>	<i>Switch on voltage (V)</i>
Green	2.0
Red	1.4
Yellow	1.7

Using the table, state a possible value for the switch on voltage of an LED that emits blue light.

1

- (c) The remote control for a television contains an LED.

The graph below shows the range of wavelengths emitted by the LED and the relative light output.

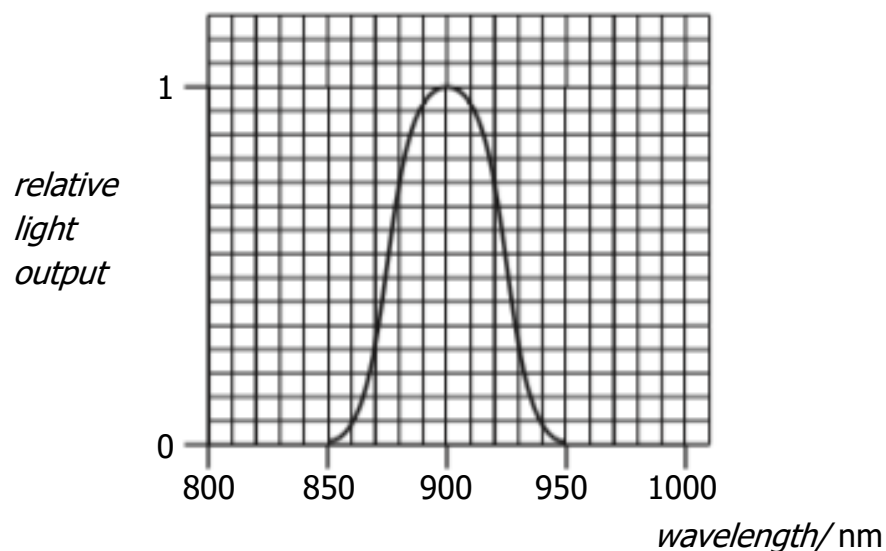

Calculate the maximum energy of a photon emitted from this LED.

4

## Band Theory and Conductivity

20. Solids can be categorised as conductors, insulators or semiconductors depending on their ability to conduct electricity. Their electrical conductivity can be explained using band theory.

The diagrams show the valence and conduction bands of three solids X, Y and Z.

One represents a conductor, one represents an insulator and one represents a semiconductor.

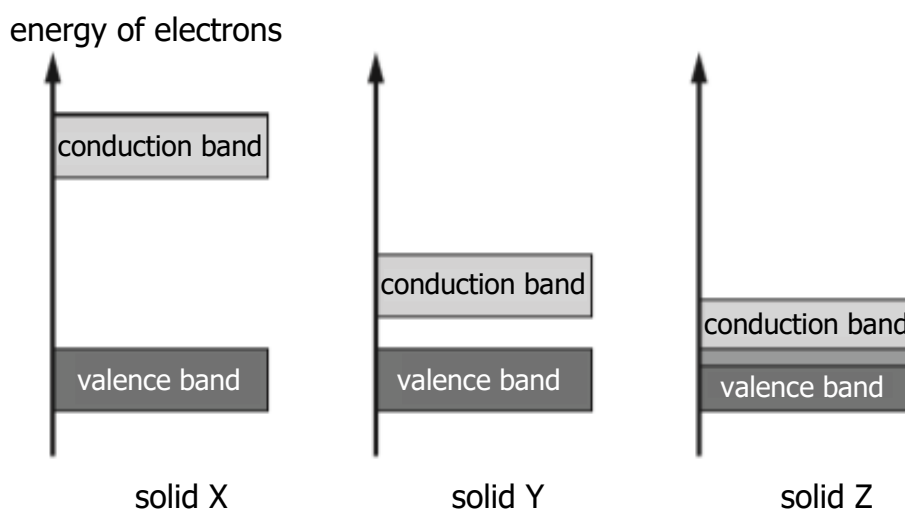

- (a) Copy and complete the table below to show which solid represents a conductor, an insulator and a semiconductor. 1

Solid	Category
X	
Y	
Z	

- (b) Using band theory, explain why electrical conduction can take place in a semiconductor at room temperature. 2
- (c) Silicon can be doped with arsenic to produce an n-type semiconductor. State the effect that doping has on the electrical conductivity of silicon. 1

Band Theory and Conductivity; Practical Circuits

21. (a) A student carries out an experiment using a solar cell connected to a variable resistor R as shown.

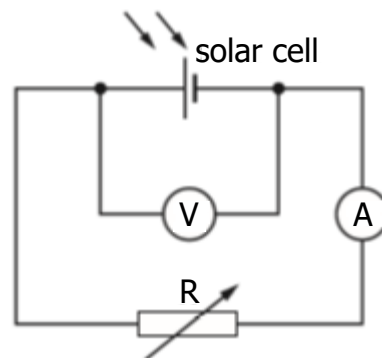

A lamp is placed above the solar cell and switched on.

The variable resistor is altered and readings of current and voltage are taken. These readings are used to produce the following graph.

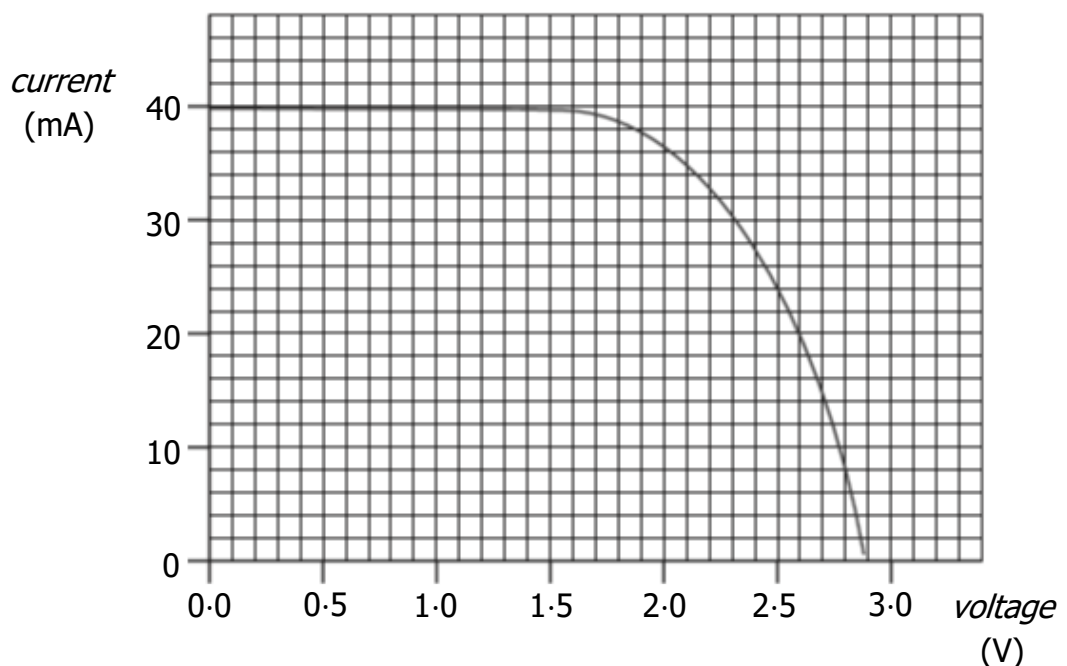

- (a) Solar cells have a maximum power output for a particular irradiance of light.

In this experiment the maximum power output occurs when the voltage is 2.1 V.

Use information from the graph to estimate a value for the maximum power output from the solar cell.

3

- (b) The lamp is now moved closer to the solar cell.

Explain, in terms of photons, why the maximum output power from the solar cell increases.

1



Band Theory and Conductivity; Open Ended

22. A student is describing how the following circuit works.

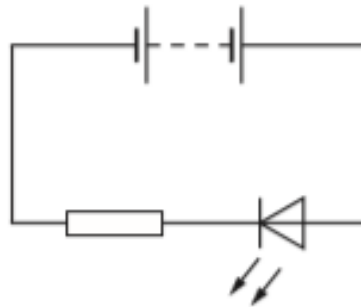

The student states:

"The electricity comes out of the battery with energy and flows through the resistor using up some of the energy, it then goes through the LED and the rest of the energy is changed into light waves."

Use your knowledge of physics to comment on this statement.

3

## Practical Circuits

1. In the following circuit, the supply has negligible internal resistance.

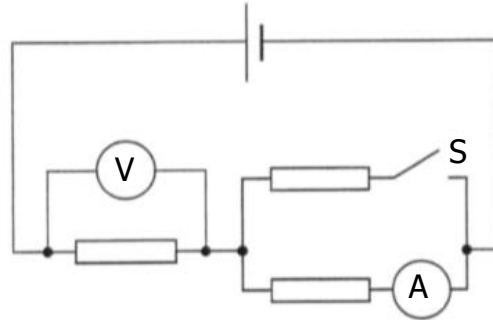

Switch S is now closed.

Which row in the table shows the effect on the ammeter and voltmeter readings?

	<i>Ammeter reading</i>	<i>Voltmeter reading</i>
A	increases	increases
B	increases	decreases
C	decreases	decreases
D	decreases	increases
E	decreases	remains the same

2. In the following circuit the current from the battery is 3 A.

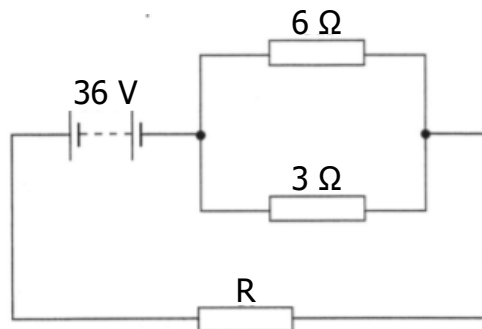

Assuming that the battery has negligible internal resistance, the resistance of resistor R is

- A 3  $\Omega$
- B 4  $\Omega$
- C 10  $\Omega$
- D 12  $\Omega$
- E 18  $\Omega$ .

3. One volt is
- A one coulomb per joule
  - B one joule coulomb
  - C one joule per coulomb
  - D one joule per second
  - E one coulomb per second.

4. Three resistors are connected as shown.

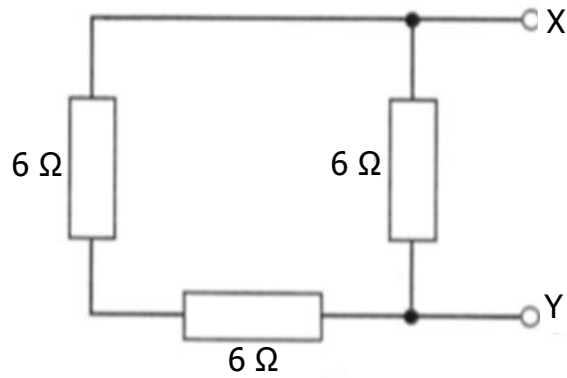

The total resistance between X and Y is

- A  $2\ \Omega$
- B  $4\ \Omega$
- C  $6\ \Omega$
- D  $9\ \Omega$
- E  $18\ \Omega$ .

5. Four resistors, each of resistance  $20\ \Omega$ , are connected to a  $60\ \text{V}$  supply of negligible internal resistance as shown below.

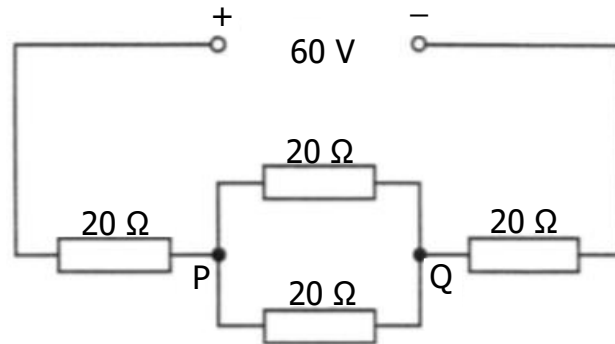

The potential difference across PQ is

- A  $12\ \text{V}$
  - B  $15\ \text{V}$
  - C  $20\ \text{V}$
  - D  $24\ \text{V}$
  - E  $30\ \text{V}$ .
6. A battery of e.m.f.  $24\ \text{V}$  and a negligible internal resistance is connected as shown.

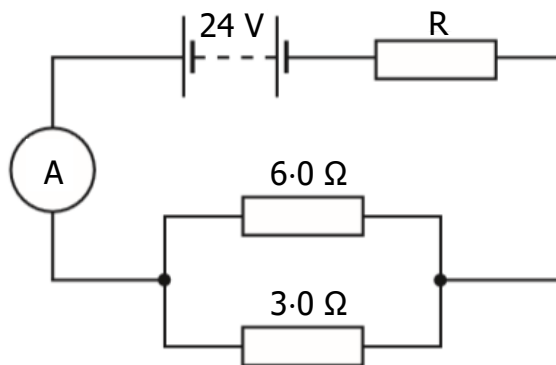

The reading on the ammeter is  $2.0\ \text{A}$ .

The resistance of R is

- A  $3.0\ \Omega$
- B  $4.0\ \Omega$
- C  $10\ \Omega$
- D  $12\ \Omega$
- E  $18\ \Omega$ .

7. Which of the following combinations of resistors has the greatest resistance between X and Y?

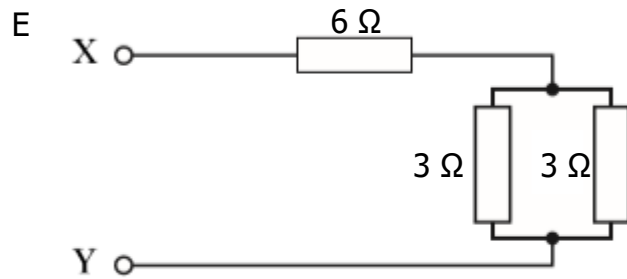
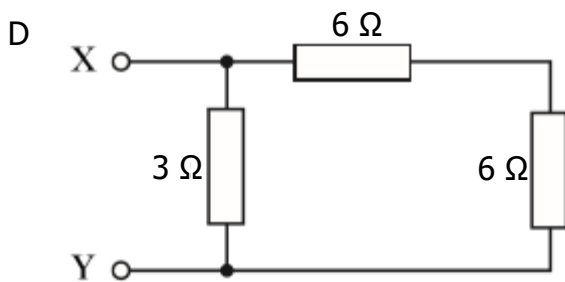
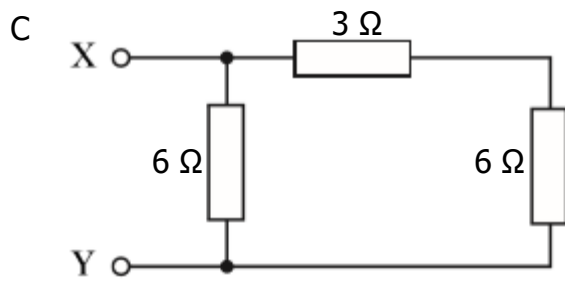
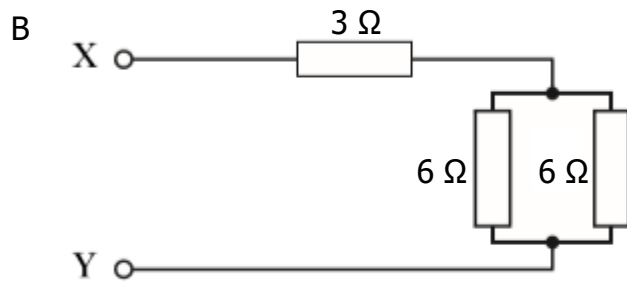
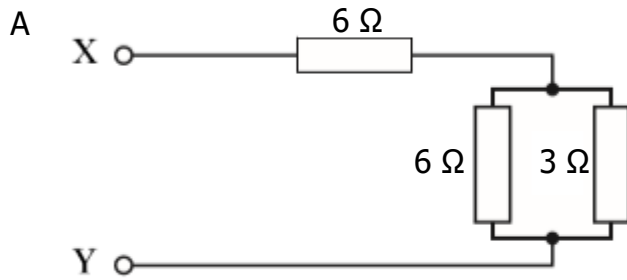

8. The diagram shows part of an electrical circuit.

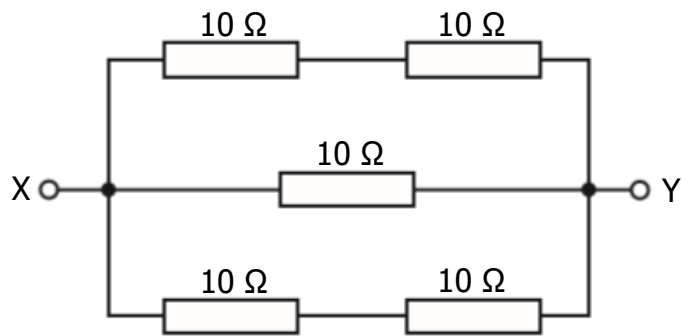

The resistance between X and Y is

- A  $0.2\ \Omega$
  - B  $5\ \Omega$
  - C  $10\ \Omega$
  - D  $20\ \Omega$
  - E  $50\ \Omega$ .
9. The following circuit is set up.

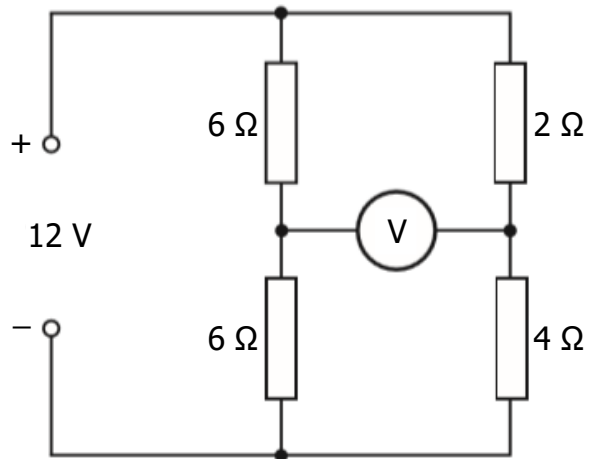

The reading on the voltmeter is

- A  $0\ \text{V}$
- B  $2\ \text{V}$
- C  $6\ \text{V}$
- D  $8\ \text{V}$
- E  $12\ \text{V}$ .

10. Five resistors are connected as shown.

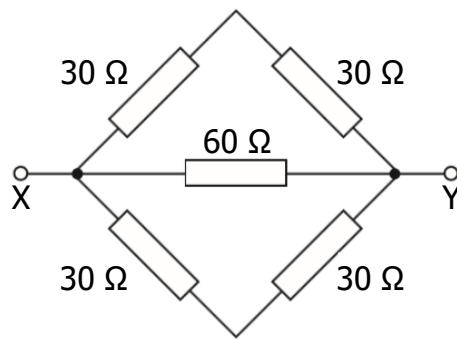

The resistance between X and Y is

- A 12  $\Omega$
  - B 20  $\Omega$
  - C 30  $\Omega$
  - D 60  $\Omega$
  - E 180  $\Omega$ .
11. A circuit is set up as shown.

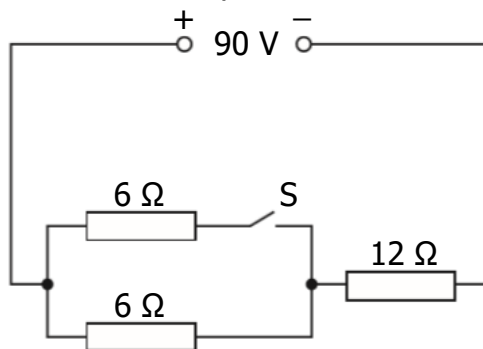

The internal resistance of the supply is negligible.

Which row in the table shows the potential difference (p.d.) across the 12  $\Omega$  resistor when switch S is open and when S is closed?

	<i>p.d. across 12 <math>\Omega</math> resistor when S is open / V</i>	<i>p.d. across 12 <math>\Omega</math> resistor when S is closed / V</i>
A	30	18
B	45	45
C	60	45
D	60	72
E	72	60

12. A potential divider circuit is set up as shown.

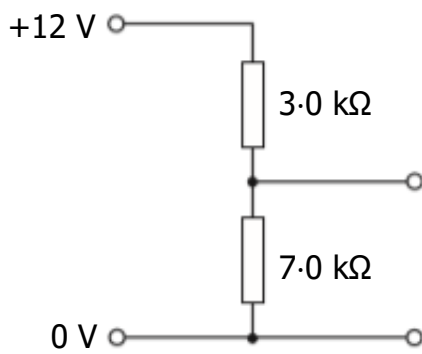

The potential difference across the 7.0 kΩ resistor is

- A 3.6 V
  - B 4.0 V
  - C 5.1 V
  - D 8.4 V
  - E 9.0 V.
13. The power dissipated in a 120 Ω resistor is 4.8 W.
- The current in the resistor is
- A 0.020 A
  - B 0.040 A
  - C 0.20 A
  - D 5.0 A
  - E 25 A.



14. A circuit is set up in which the battery has negligible internal resistance.

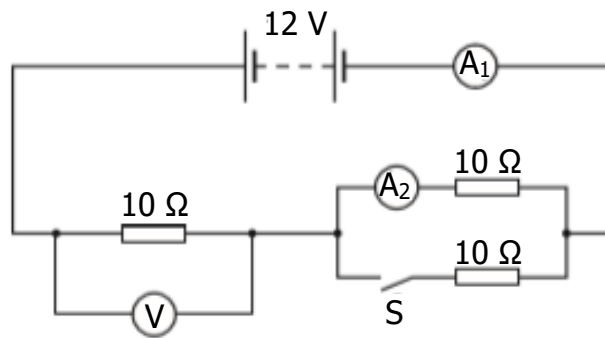

A student makes the following statements about the readings on the meters in this circuit.

- I When switch S is open the reading on the voltmeter will be 6.0 V.
- II When switch S is open the reading on  $A_2$  will be 0.6 A.
- III When switch S is closed the reading on  $A_1$  will be 0.80 A.

Which of these statements is/are correct?

- A I only
  - B II only
  - C I and II only
  - D II and III only
  - E I, II and III
15. A circuit is set up in which the battery has negligible internal resistance.

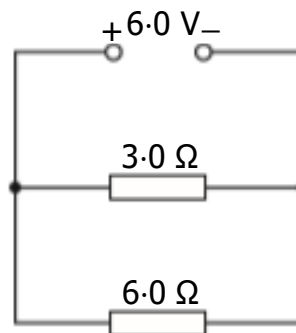

The power dissipated in the 3.0  $\Omega$  resistor is

- A 3.0 W
- B 6.0 W
- C 9.0 W
- D 12 W
- E 18 W.

16. A student connects four identical light emitting diodes (LEDs) to a 2 V DC supply as shown.

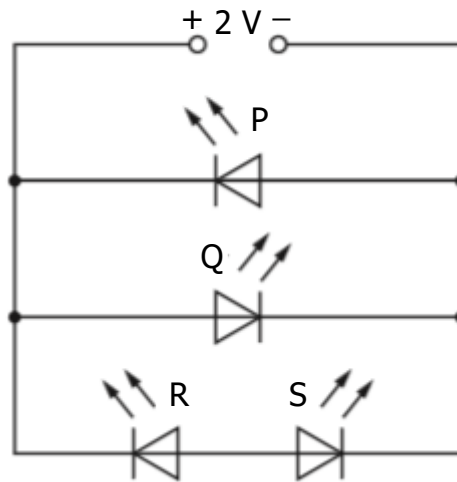

Which of the LEDs P, Q, R and S will light?

- A P only
- B Q only
- C P and Q only
- D P and R only
- E Q and S only

## Capacitance

1. The unit for capacitance can be written as
- A  $V C^{-1}$
  - B  $C V^{-1}$
  - C  $J s^{-1}$
  - D  $C J^{-1}$
  - E  $J C^{-1}$ .
2. A student carries out three experiments to investigate the charging of a capacitor using a d.c. supply.

The graphs obtained from the experiments are shown.

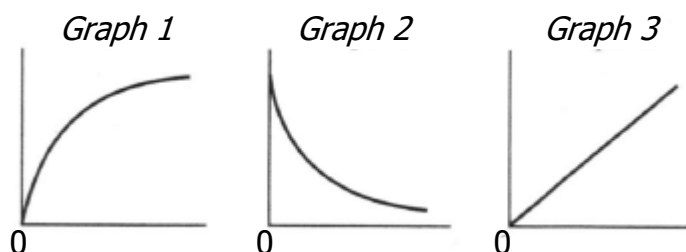

The axes of the graphs have not been labelled.

Which row in the table shows the labels for the axes of the graphs?

<i>Graph 1</i>	<i>Graph 2</i>	<i>Graph 3</i>
voltage and time	current and time	charge and voltage
current and time	voltage and time	charge and voltage
current and time	charge and voltage	voltage and time
charge and voltage	current and time	voltage and time
voltage and time	charge and voltage	current and time

3. A  $25.0 \mu\text{F}$  capacitor is charged until the potential difference across it is  $500 \text{ V}$ .

The charge stored on the capacitor is

- A  $5.00 \times 10^{-8} \text{ C}$
- B  $2.00 \times 10^{-5} \text{ C}$
- C  $1.25 \times 10^{-2} \text{ C}$
- D  $1.25 \times 10^4 \text{ C}$
- E  $2.00 \times 10^7 \text{ C}$ .

4. A circuit is set up as shown.

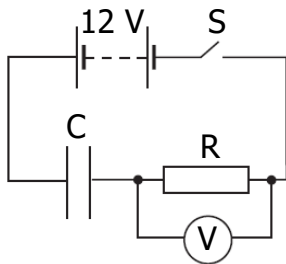

The capacitor is initially uncharged. Switch S is now closed. Which graph shows how the potential difference,  $V$ , across R, varies with time  $t$ ?

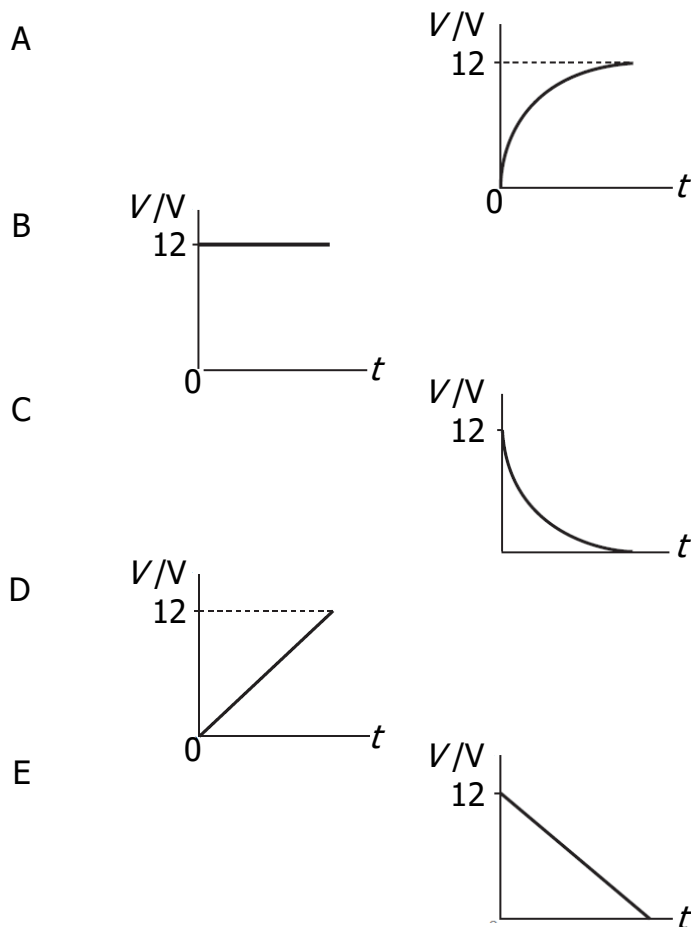

5. A student carries out an experiment to find the capacitance of a capacitor. The charge on the capacitor is measured for different values of p.d. across the capacitor. The results are shown.

<i>charge on capacitor / <math>\mu\text{C}</math></i>	<i>p.d. across capacitor / V</i>
1.9	1.0
4.6	2.0
9.6	4.0

The best estimate of the capacitance is

- A 1.9  $\mu\text{F}$
  - B 2.2  $\mu\text{F}$
  - C 2.3  $\mu\text{F}$
  - D 2.4  $\mu\text{F}$
  - E 2.6  $\mu\text{F}$ .
6. The capacitance of a capacitor is 1000  $\mu\text{F}$ . The potential difference (p.d.) across the capacitor is 100 V. The charge stored by the capacitor is 0.10 C.

The charge on the capacitor is now reduced to half its original value.

Which row in the table shows the capacitance of the capacitor and the p.d. across the capacitor for this new value of charge?

<i>Capacitance / <math>\mu\text{F}</math></i>	<i>p.d. / V</i>
1000	200
500	100
1000	100
500	50
1000	50

7. The graph shows how the charge,  $Q$ , stored on a capacitor varies with the potential difference,  $V$ , across the capacitor.

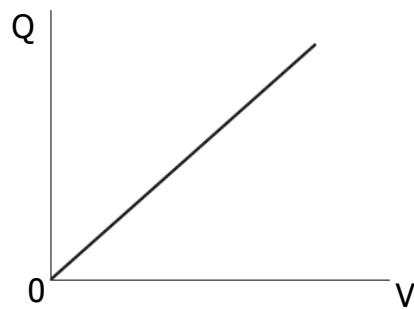

Which of the following statements is/are correct?

- I The gradient of the graph represents the capacitance of the capacitor.
  - II The area under the graph represents the work done in charging the capacitor.
  - III The energy,  $E$ , stored in the capacitor is given by the equation  $E = QV$ .
- A I only  
B II only  
C III only  
D I and II only  
E I, II and III
8. A capacitor has a capacitance of  $20 \mu\text{F}$ .  
The energy stored on the capacitor is  $4.0 \text{ mJ}$ .  
The potential difference across the capacitor is
- A  $5.0 \text{ V}$
  - B  $20 \text{ V}$
  - C  $80 \text{ V}$
  - D  $200 \text{ V}$
  - E  $400 \text{ V}$ .

9. A  $20\ \mu\text{F}$  capacitor is connected to a  $12\ \text{V}$  d.c. supply.

The maximum charge stored on the capacitor is

- A  $1.4 \times 10^{-3}\ \text{C}$
- B  $2.4 \times 10^{-4}\ \text{C}$
- C  $1.2 \times 10^{-4}\ \text{C}$
- D  $1.7 \times 10^{-6}\ \text{C}$
- E  $6.0 \times 10^{-7}\ \text{C}$ .

10. A circuit containing a capacitor is set up as shown.

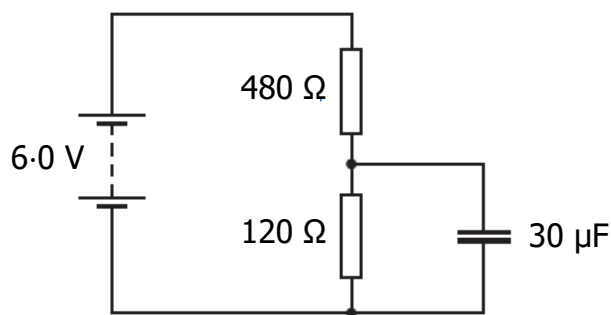

The supply has negligible internal resistance.

The maximum energy stored in the capacitor is

- A  $5.4 \times 10^{-4}\ \text{J}$
  - B  $3.5 \times 10^{-4}\ \text{J}$
  - C  $1.4 \times 10^{-4}\ \text{J}$
  - D  $3.4 \times 10^{-5}\ \text{J}$
  - E  $2.2 \times 10^{-5}\ \text{J}$ .
11. A  $24.0\ \mu\text{F}$  capacitor is charged until the potential difference across it is  $125\ \text{V}$ .

The charge stored on the capacitor is

- A  $5.21 \times 10^6\ \text{C}$
- B  $7.75 \times 10^{-2}\ \text{C}$
- C  $1.50 \times 10^{-3}\ \text{C}$
- D  $3.00 \times 10^{-3}\ \text{C}$
- E  $1.92 \times 10^{-7}\ \text{C}$ .

12. A circuit is set up as shown.

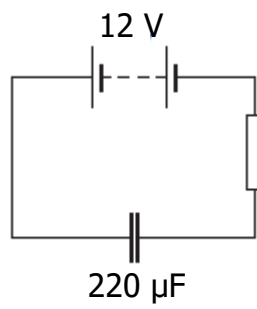

When the capacitor is fully charged the energy stored in the capacitor is

- A  $1.6 \times 10^{-5} \text{ J}$
- B  $1.3 \times 10^{-3} \text{ J}$
- C  $2.6 \times 10^{-3} \text{ J}$
- D  $1.6 \times 10^{-2} \text{ J}$
- E  $1.6 \times 10^4 \text{ J}$ .



13. The circuit shown is used to charge and then discharge a capacitor C.

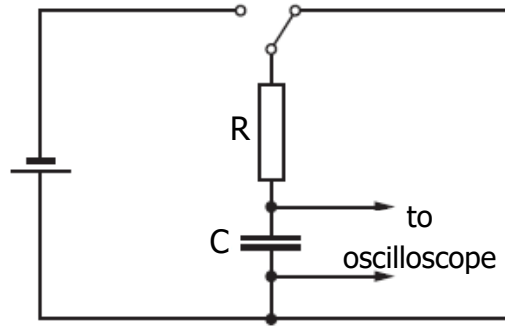

Which pair of graphs shows how the potential difference  $V$  across the capacitor varies with time  $t$  during charging and discharging?

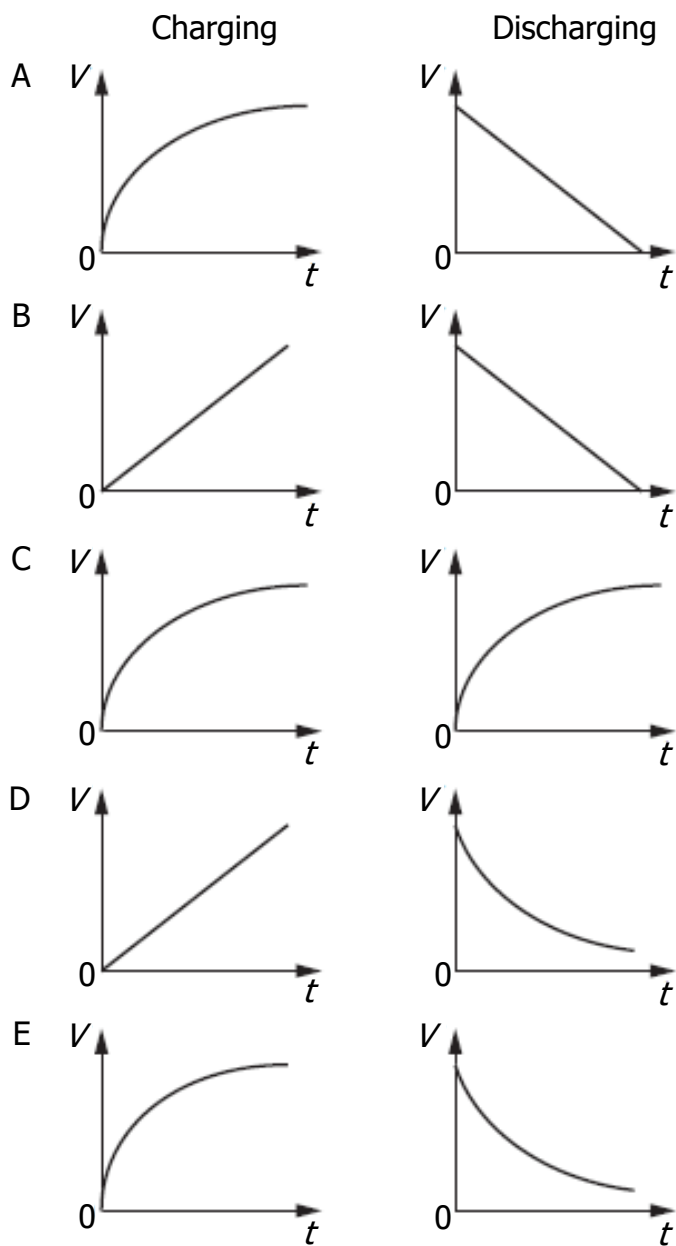

Capacitance; Line Spectra

14. (a) The following diagram shows a circuit that is used to investigate the charging of a capacitor.

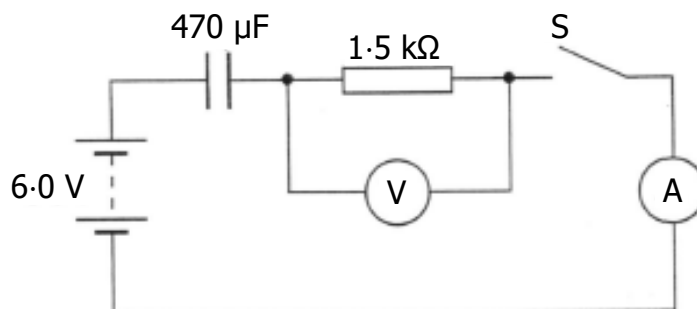

The capacitor is initially uncharged.

The capacitor has a capacitance of  $470 \mu\text{F}$  and the resistor has a resistance of  $1.5 \text{ k}\Omega$ .

The battery has an e.m.f. of  $6.0 \text{ V}$  and negligible internal resistance.

- (i) Switch S is now closed. Calculate the initial current in the circuit. 3
- (ii) Calculate the maximum energy stored by the capacitor. 3
- (iii) State a change that could be made to ensure the **same** capacitor stores more energy. 1
- (b) A capacitor is used to provide the energy for an electronic flash in a camera.
- When the flash is triggered,  $6.35 \times 10^{-3} \text{ J}$  of the stored energy is emitted as light.
- The mean value of the frequency of photons of light from the flash is  $5.80 \times 10^{14} \text{ Hz}$ .
- Calculate the total number of photons emitted in each flash of light. 4

## Capacitance

15. The circuit below is used to investigate the charging of a  $2000\ \mu\text{F}$  capacitor. The d.c. supply has negligible internal resistance.

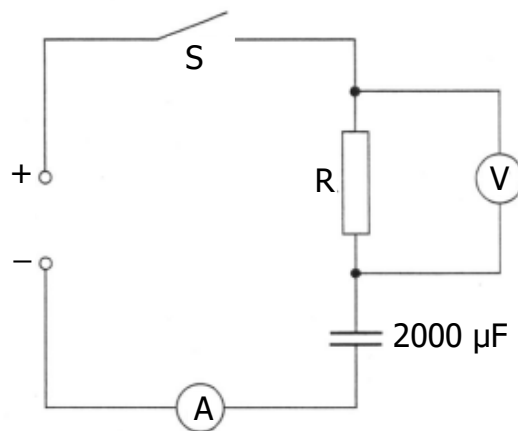

The graphs below show how the potential difference  $V_R$  across the resistor and the current  $I$  in the circuit vary with time from the instant switch S is closed.

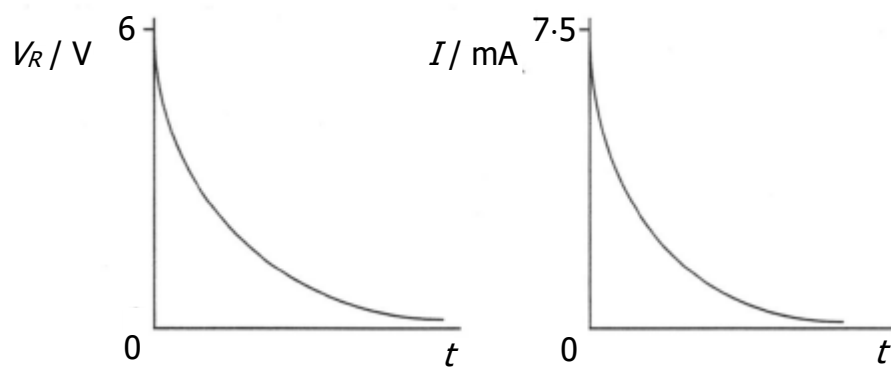

- (a) State the potential difference across the capacitor when it is fully charged. 1
- (b) Calculate the maximum energy stored by the capacitor. 3
- (c) Calculate the resistance of R in the circuit above. 3

## Capacitance

16. In an experiment, the circuit shown is used to investigate the charging of a capacitor.

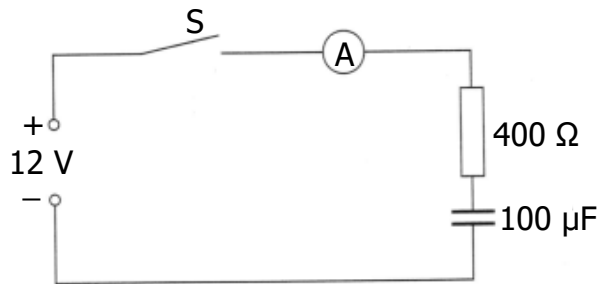

The power supply has an e.m.f. of 12 V and negligible internal resistance. The capacitor is initially uncharged.

Switch S is closed and the current is measured during charging. The graph of charging current against time is shown in figure 1.

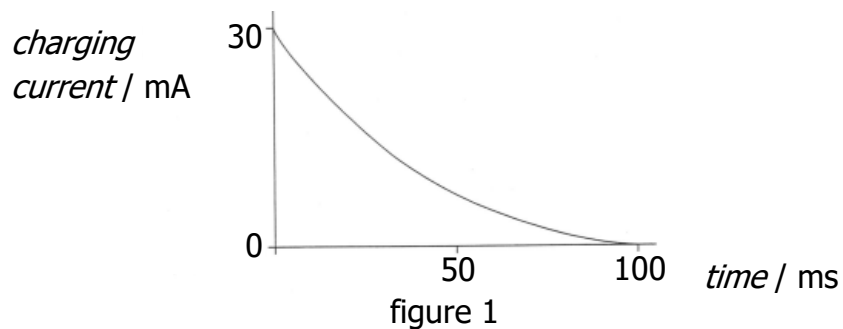

- (a) Sketch a graph of voltage across the capacitor against time until the capacitor is fully charged. Numerical values are required on both axes. 2
- (b) (i) Calculate the voltage across the capacitor when the charging current is 20 mA. 4
- (ii) Calculate the energy stored by the capacitor when the charging current is 20 mA. 3
- (c) The 100 μF capacitor is now replaced by an uncharged capacitor of unknown capacitance and the experiment is repeated. The graph of charging current against time for this capacitor is shown in figure 2.

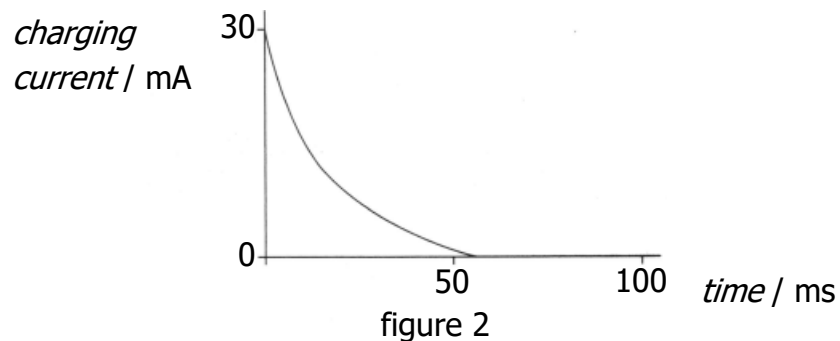

By comparing figure 2 with figure 1, determine whether the capacitance of this capacitor is greater than, equal to or less than 100 μF.

You must explain your answer.

2

## Capacitance

17. A student investigates the charging and discharging of a  $2200\ \mu\text{F}$  capacitor using the circuit shown.

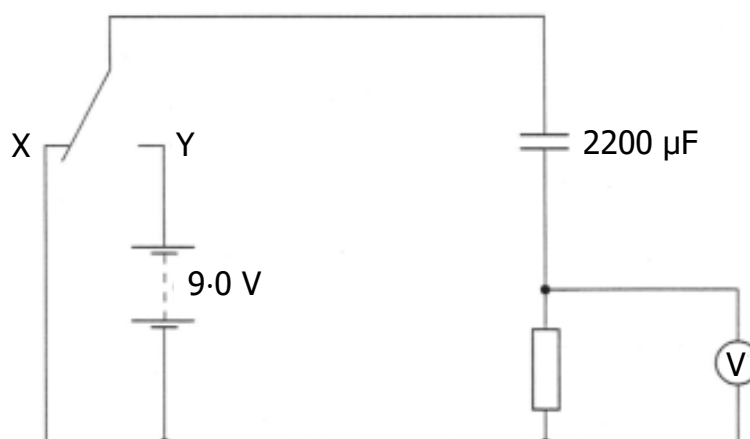

The  $9.0\ \text{V}$  battery has negligible internal resistance.

Initially the capacitor is uncharged and the switch is at position X.

The switch is then moved to position Y and the capacitor charges fully in  $1.5\ \text{s}$ .

- (a) (i) Sketch a graph of the potential difference across the **resistor** against time while the capacitor charges. Numerical values are required on both axes. 2
- (ii) The resistor is replaced with one of higher resistance. Explain how this affects the time taken to fully charge the capacitor. 2
- (iii) At one instant during the charging of the capacitor the reading on the voltmeter is  $4.0\ \text{V}$ . Calculate the charge stored by the capacitor at this instant. 4
- (b) Using the same circuit in a later investigation the resistor has a resistance of  $100\ \text{k}\Omega$ . The switch is in **position Y** and the capacitor is fully charged.
- (i) Calculate the maximum energy stored in the capacitor. 3
- (ii) The switch is moved to position X. Calculate the maximum current in the resistor. 3

Capacitance; Practical Circuits

18. The 9.0 V battery in the circuit shown below has negligible internal resistance.

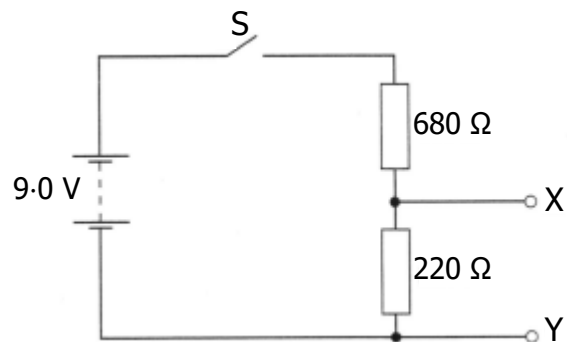

- (a) Switch S is closed.

Calculate the potential difference between X and Y.

3

- (b) Switch S is opened.

An uncharged 33  $\mu\text{F}$  capacitor is connected between X and Y as shown.

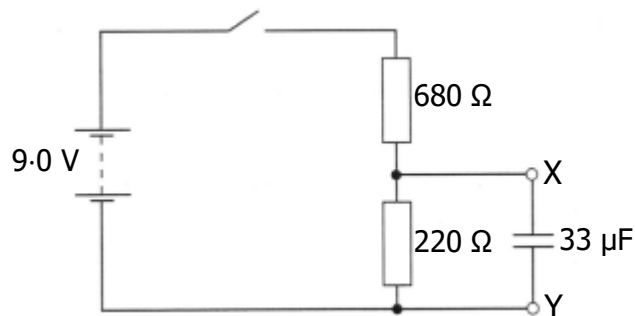

Switch S is then closed.

- (i) Explain why work is done in charging the capacitor. 1
- (ii) State the value of the maximum potential difference across the capacitor in this circuit. 1
- (iii) Calculate the maximum energy stored by the capacitor. 3
- (iv) Switch S is now opened.

Sketch a graph to show how the current through the 220  $\Omega$  resistor varies with time from the moment the switch is opened.

Numerical values are required only on the current axis. 2

## Capacitance

19. An uncharged  $2200\ \mu\text{F}$  capacitor is connected in a circuit as shown.

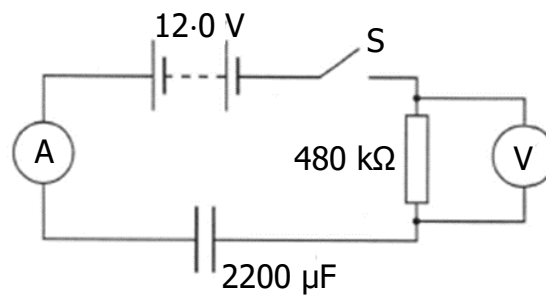

The battery has negligible internal resistance.

- (a) Switch S is closed.

Calculate the initial charging current.

3

- (b) At one instant during the charging process the potential difference across the resistor is 3.8 V.

Calculate the charge stored by the capacitor at this instant.

4

- (c) Calculate the **maximum** energy the capacitor stores in the this circuit.

3

Capacitance; Practical Circuits

20. (a) State what is meant by the term capacitance. 1
- (b) An uncharged capacitor,  $C$ , is connected in a circuit as shown.

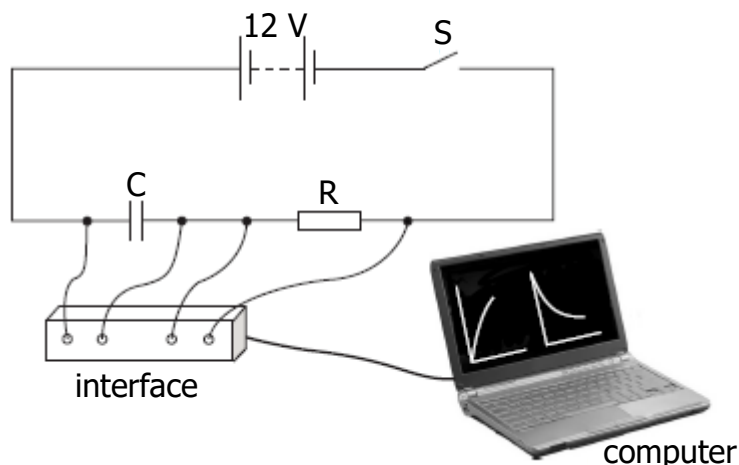

The 12 V battery has negligible internal resistance.

Switch S is closed and the capacitor begins to charge.

The interface measures the potential difference (p.d.) across the capacitor and the current in the circuit. These measurements are displayed as graphs on the computer.

Graph 1 shows the p.d. across the capacitor for the first 0.40 s of charging.

Graph 2 shows the current in the circuit for the first 0.40 s of charging.

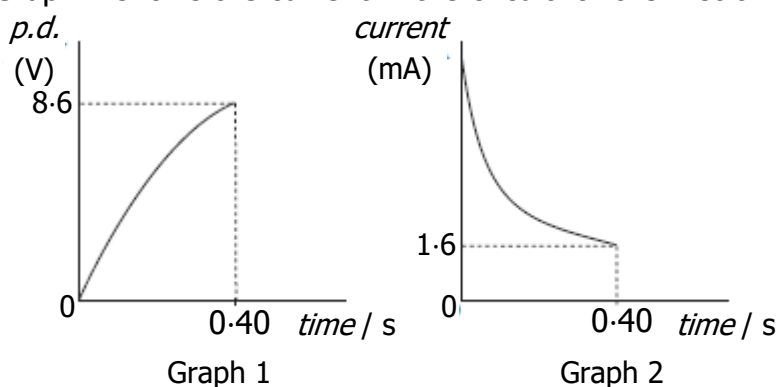

- (i) Determine the p.d. **across resistor R** at 0.40 s. 1
- (ii) Calculate the resistance of R. 3
- (iii) The capacitor takes 2.2 seconds to charge fully.  
At that time it stores 10.8 mJ of energy.  
Calculate the capacitance of the capacitor. 3



20. **(continued)**

(c) The capacitor is now discharged.

A second, identical resistor is connected in the circuit as shown.

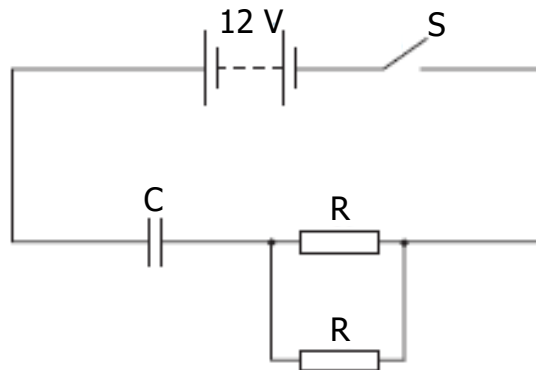

Switch S is closed.

Is the time taken for the capacitor to fully charge less than, equal to, or greater than the time taken to fully charge in part (b)?

Justify your answer.

2

## Capacitance

21. A 12 volt battery of negligible internal resistance is connected in a circuit as shown.

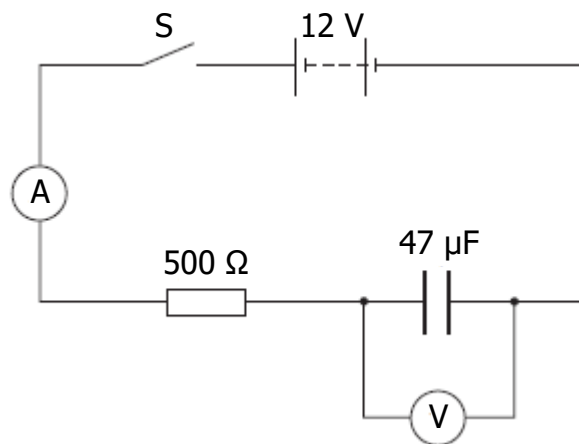

The capacitor is initially uncharged. Switch S is then closed and the capacitor starts to charge.

- (a) Sketch a graph of the current against time from the instant switch S is closed. Numerical values are **not** required. 1
- (b) At one instant during the charging of the capacitor the reading on the ammeter is 5.0 mA.

Calculate the reading on the voltmeter at this instant. 4

- (c) Calculate the maximum energy stored by the capacitor in this circuit. 3
- (d) The 500 Ω resistor is now replaced with a 2.0 kΩ resistor.

State the effect, if any, that this will have on the maximum energy stored in the capacitor.

Justify your answer. 2

## Capacitance

22. A student carries out an experiment using a circuit which includes a capacitor with a capacitance of  $200\ \mu\text{F}$ .

- (a) State what is meant by a *capacitance of  $200\ \mu\text{F}$* . 1
- (b) The capacitor is used in the circuit shown to measure the time taken for a ball to fall vertically between two strips of metal foil.

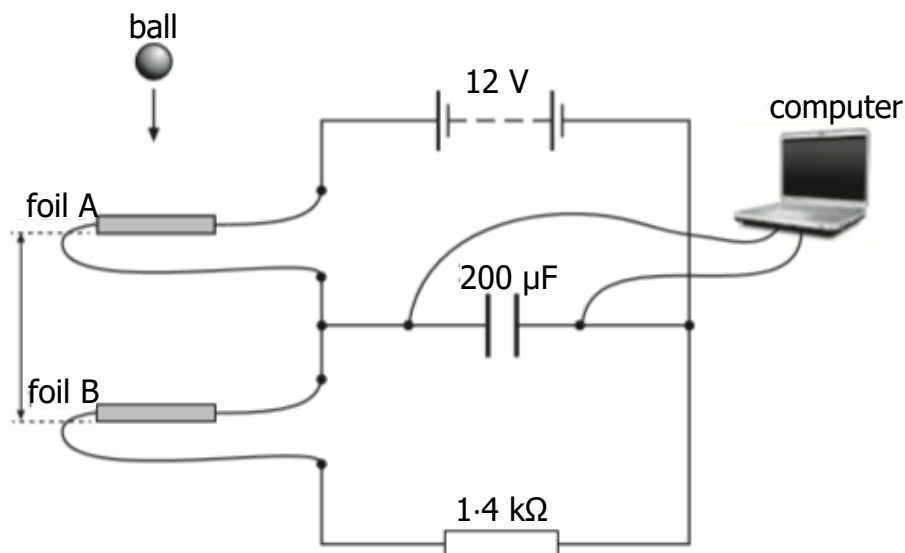

The ball is dropped from rest above foil A. It breaks through foil A then breaks through foil B a short time later.

The computer displays a graph of potential difference across the capacitor against time as shown.

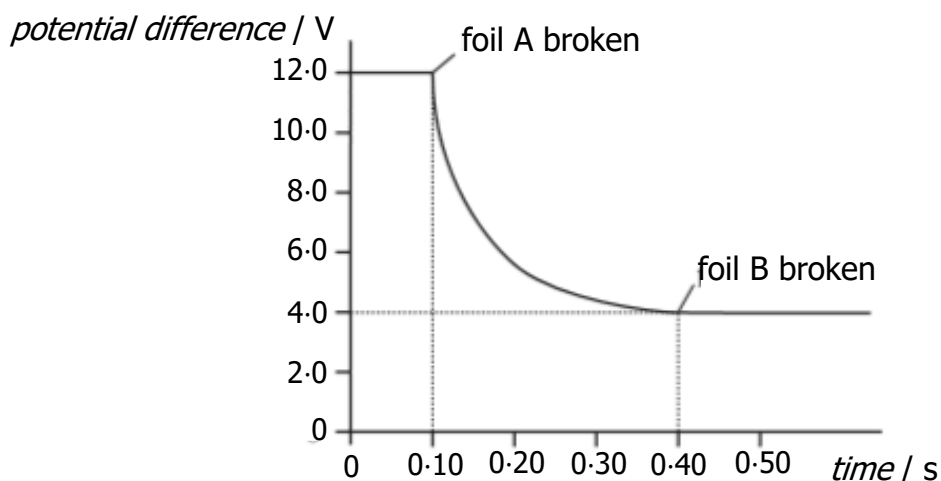

- (i) Calculate the current in the  $1.4\ \text{k}\Omega$  resistor at the exact moment foil A is broken. 3
- (ii) Calculate the **decrease** in the energy stored in the capacitor during the time taken for the ball to fall from foil A to foil B. 4

## Capacitance

23. The charging and discharging of a capacitor are investigated using the circuit shown.

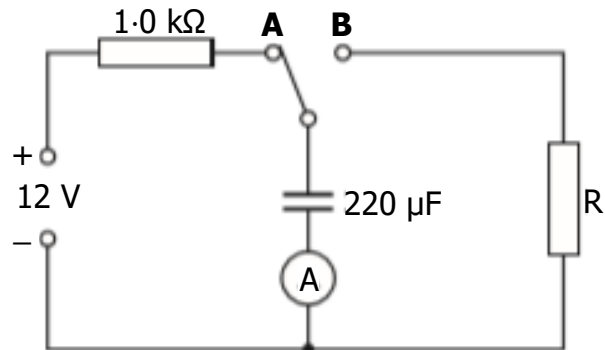

The power supply has an e.m.f. of 12 V and negligible internal resistance. The capacitor is initially uncharged.

- (a) The switch is connected to **A** and the capacitor starts to charge. Sketch a graph showing how the voltage across the plates of the capacitor varies with time. Your graph should start from the moment the switch is connected to **A** until the capacitor is fully charge.

Numerical values are only required on the voltage axis.

2

- (b) The capacitor is now discharged by moving the switch to **B**.

The graph of current against time as the capacitor discharges is shown.

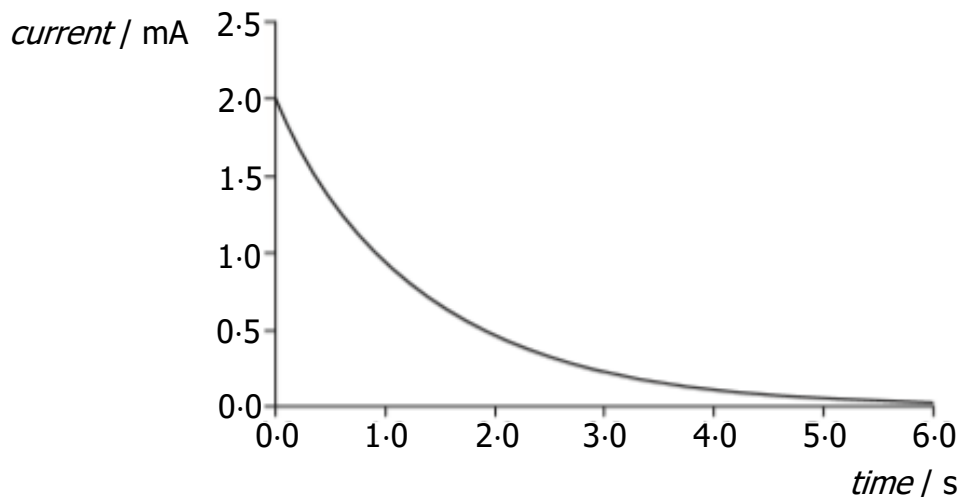

Calculate the resistance of R.

3

23. **(continued)**

- (c) The  $220\ \mu\text{F}$  capacitor is now replaced with one of different value. This new capacitor is fully charged by moving the switch to **A**. It is then discharged by moving the switch to **B**.

The graph of current against time as this capacitor discharges is shown.

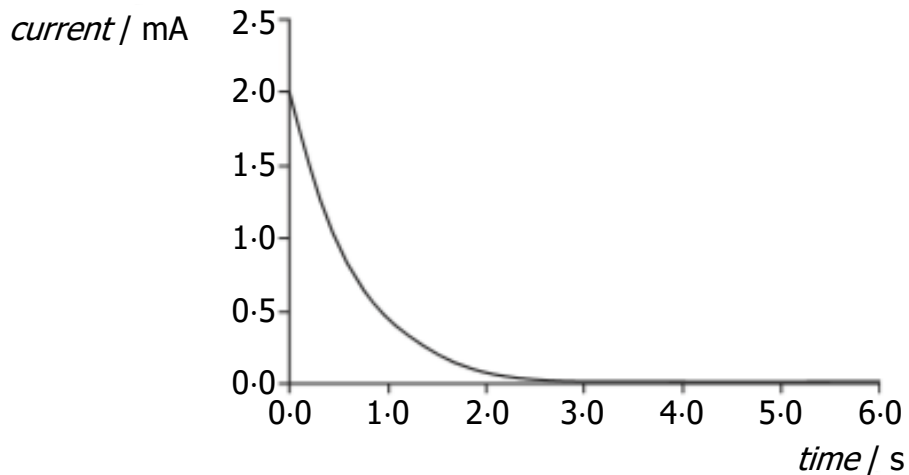

- (i) Explain why the value of the initial discharging current remains the same as in part (b). 1
- (ii) State whether the capacitance of this capacitor is greater than, equal to, or less than the capacitance of the original  $220\ \mu\text{F}$  capacitor. 2

You must justify your answer.

## Capacitance

24. Part of a camera flash circuit operates at 250 V d.c. The circuit includes a  $15.0 \text{ k}\Omega$  resistor and a  $470 \text{ }\mu\text{F}$  capacitor. The capacitor is initially uncharged.

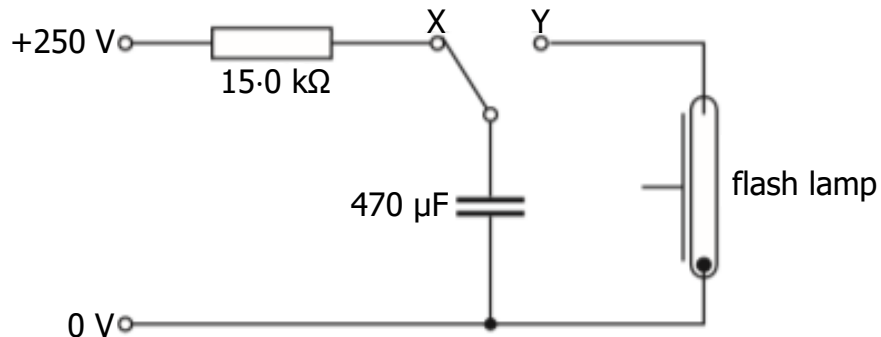

- (a) The capacitor is now charged by connecting the switch to X.
- (i) Calculate the initial charging current. 3
  - (ii) Sketch a graph to show how the voltage across the capacitor varies with time from the moment the switch is connected to X. Numerical values are required on the voltage axis. 2
  - (iii) Show that the energy stored by the capacitor is  $14.7 \text{ J}$  when it is fully charged. 2
- (b) When a flash photograph is taken, the switch is connected to Y and the capacitor discharges through the flash lamp in a time of  $200 \text{ }\mu\text{s}$ .  
Calculate the average power output of the flash lamp. 3
- (c) The flash cannot be fired again for another photograph until the capacitor has recharged. The time for this to happen is called the recycle time.  
State how the circuit could be modified to reduce the recycle time without altering the power output of the flash. 1

## Capacitance

25. A student sets up the circuit shown to investigate the charging of a capacitor.

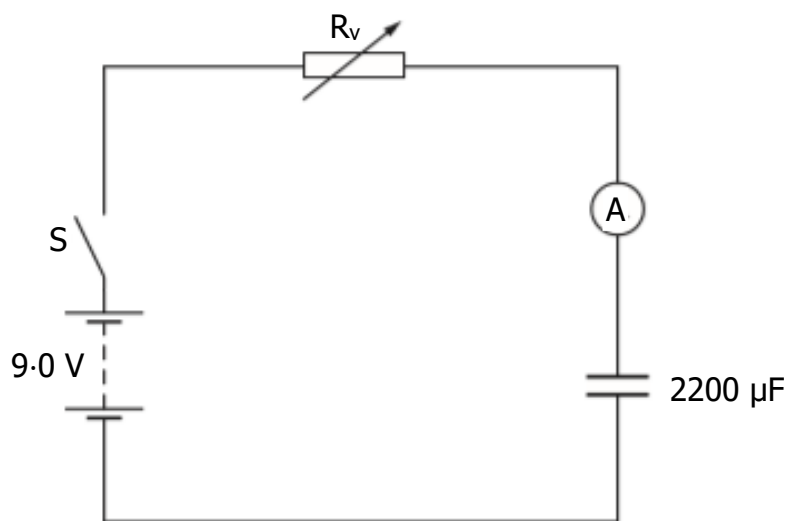

The battery has an e.m.f. of 9.0 V and negligible internal resistance.

Initially the capacitor is uncharged and the variable resistor  $R_v$  is set to 12 k $\Omega$ .

- (a) Switch S is now closed and the capacitor charges.

Sketch a graph of the current in the circuit against time from the moment the switch is closed until the capacitor is fully charged.

Numerical values are only required on the current axis.

2

- (b) Capacitors have an insulator between their plates.

Explain why there is a current in the circuit during the charging process.

1

- (c) At one instant during the charging process, the current in the 12 k $\Omega$  resistor is  $5.0 \times 10^{-4}$  A.

Calculate the charge stored on the capacitor at this time.

4

- (d) Switch S is now opened and the capacitor is fully discharged. The variable resistor is adjusted to a greater resistance.

Switch S is closed and the capacitor charges again.

State and explain what effect, if any, this increase in resistance has on:

(i) the maximum potential difference across the capacitor;

2

(ii) the maximum current in the circuit.

2

## Capacitance

26. A defibrillator is a device that provides a high energy electrical impulse to correct abnormal heart beats.



paddle A      paddle B

The diagram shows a simplified version of a defibrillator circuit.

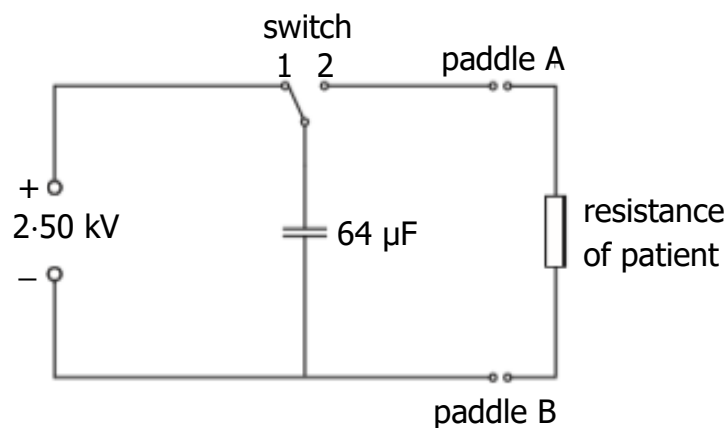

The switch is set to position 1 and the capacitor charges.

- (a) Show the charge on the capacitor when it is fully charged is 0.16 C .      2
- (b) Calculate the maximum energy stored by the capacitor.      3
- (c) To provide the electrical impulse required the capacitor is discharged through the person's chest using the paddles as shown.



The initial discharge current through the person is 35.0 A.

- (i) Calculate the effective resistance of the part of the person's body between the paddles.      3



26. (c) (continued)

- (ii) The graph shows how the current between the paddles varies with time during the discharge of the capacitor.

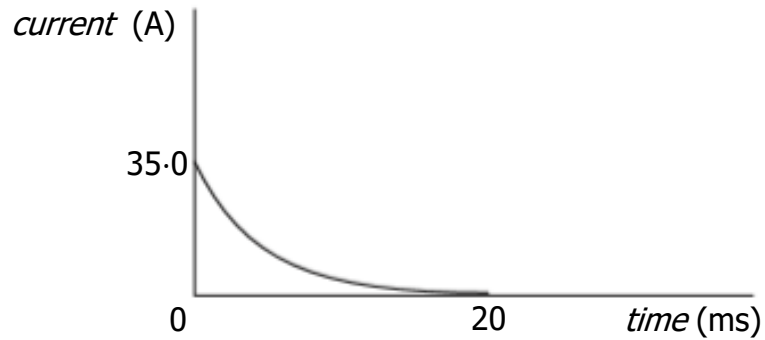

The effective resistance of the person remains the same during this time.

Explain why the current decreases with time.

1

- (iii) The defibrillator is used on a different person with larger effective resistance. The capacitor is again charged to 2.50 kV.

Sketch the graph in part (c)(ii), then add a line to show how the current in this person varies with time during the discharge of the capacitor. Lines **must** be labelled.

2

## Capacitance

27. A technician sets up a circuit as shown.

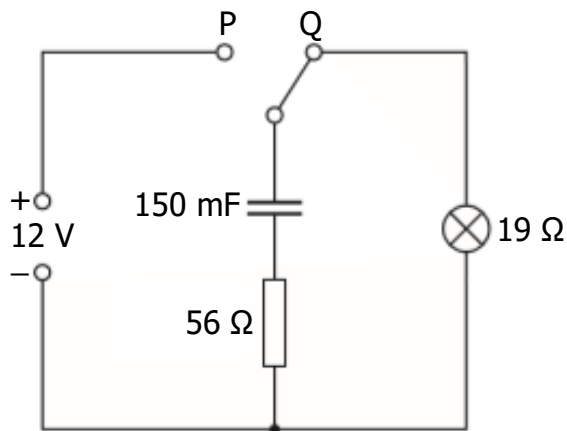

The power supply has negligible internal resistance.

(a) The capacitor is initially uncharged.

The switch is moved to position P and the capacitor charges.

(i) State the potential difference across the capacitor when it is fully charged. 1

(ii) Calculate the maximum energy stored by the capacitor. 3

(b) The switch is now moved back to position Q.

Calculate the maximum discharge current in the circuit. 3

(c) The technician replaces the 150 mF capacitor with a capacitor of capacitance 47 mF.

The switch is moved to position P and the capacitor is fully charged.

The switch is now moved to position Q.

State the effect that this change has on the time the lamp stays lit.

You must justify your answer. 2

## Capacitance

28. An uncharged  $220\ \mu\text{F}$  capacitor is connected in a circuit as shown with both switches open.

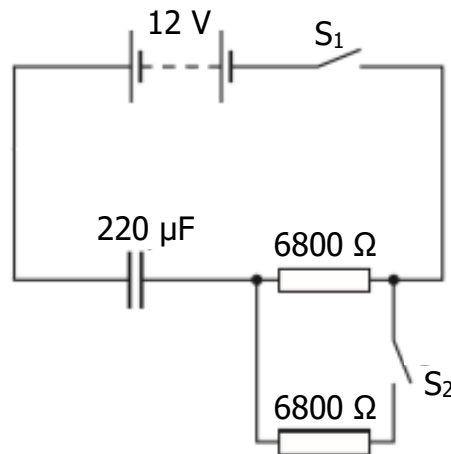

The  $12\ \text{V}$  battery has negligible internal resistance.

- (a) Switch  $S_1$  is closed and the capacitor charges in a time of  $7.5\ \text{s}$ .

Calculate the initial charging current.

3

- (b) Calculate the maximum energy stored by the capacitor in this circuit.

3

- (c) Switch  $S_1$  is opened.

The capacitor is discharged.

Switch  $S_2$  is now closed and then switch  $S_1$  is closed.

State whether the time taken for the capacitor to fully charge is greater than, equal to, or less than the  $7.5\ \text{s}$  it took when only switch  $S_1$  was closed.

You must justify your answer.

2

## Capacitance; Open Ended

29. A student investigates the charging of a capacitor.  
The student sets up the circuit as shown using a  $47\ \mu\text{F}$  capacitor.

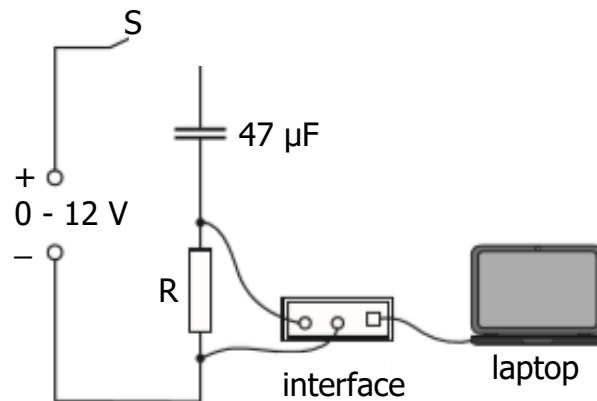

The capacitor is initially uncharged. The switch  $S$  is now closed. A laptop connected to an interface displays a graph of current against time as the capacitor charges.

- (a) The variable voltage supply is set to  $6.0\ \text{V}$ .

Calculate the maximum charge stored by the capacitor.

3

- (b) The graph shows how the current  $I$  varies with time  $t$  as the capacitor charges.

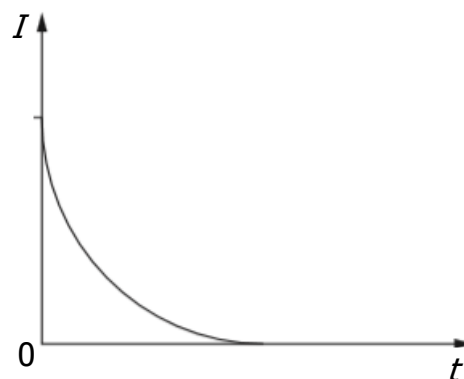

Switch  $S$  is opened and the capacitor is discharged.

The resistor  $R$  is now replaced with one that has a lesser resistance.

Switch  $S$  is again closed and the capacitor charges.

Sketch the above graph, then add a line to show how the current now varies with time as the capacitor charges. Lines **must** be labelled.

2

- (c) Suggest an alteration the student could make to this circuit to increase the maximum energy stored by the  $47\ \mu\text{F}$  capacitor.

1

29. **(continued)**

- (d) The use of analogies from everyday life can help improve the understanding of physics concepts.

Vehicles using a car park may be taken as an analogy for the charging of a capacitor.

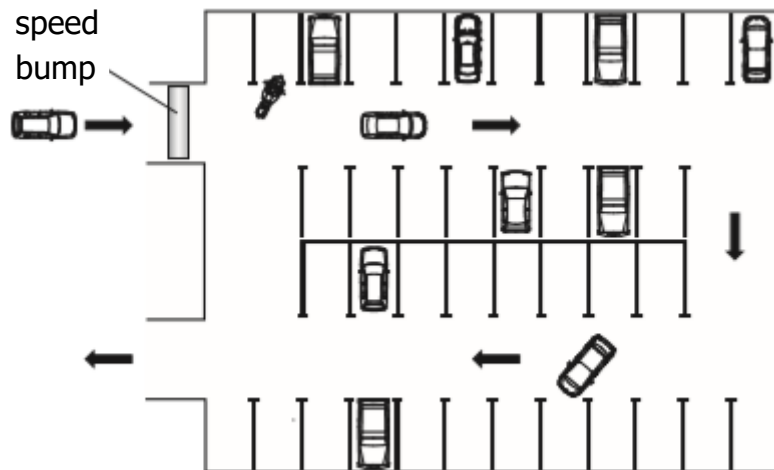

Use your knowledge of physics to comment on this analogy.

3

### Capacitance; Open Ended

30. Recent innovations in capacitor technology have led to the development of "ultracapacitors". Ultracapacitors of a similar size to standard AA rechargeable cells are now available with ratings of around 100 F with a maximum working voltage of 2.7 V.

By comparison, AA rechargeable cells operate at 1.5 V and can store up to 3400 mA h of charge.

(*charge* in mA h = *current* in mA x *time* in hours)

Use your knowledge of physics to compare the advantages and/or disadvantages of using ultracapacitors and rechargeable cells.

3