

Higher Waves  
Past Paper Questions  
Book 2

## Contents

Line Spectra

pg 2-15

Refraction

pg 16-42

## Line Spectra

1. The diagram below represents possible energy levels of an atom.

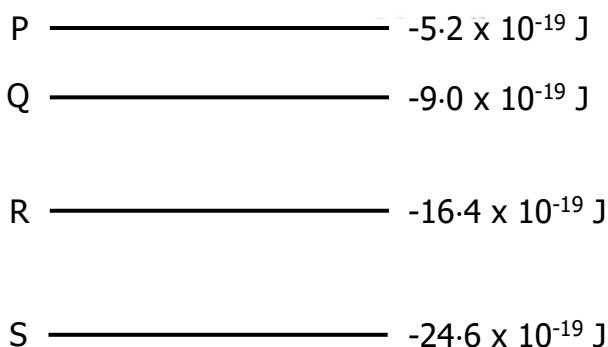

Which of the following statements is/are true?

- I There are four emission lines in the spectrum produced as a result of transitions between the energy levels shown.
- II The radiation emitted with the shortest wavelength is produced by an electron falling from level P to level S.
- III The zero energy level in an energy level diagram is known as the ionisation level.

- A I and II only
- B I and III only
- C II and III only
- D III only
- E I, II and III

2. In a laser, a photon of radiation is emitted when an electron makes a transition from a higher energy level to a lower level, as shown below.

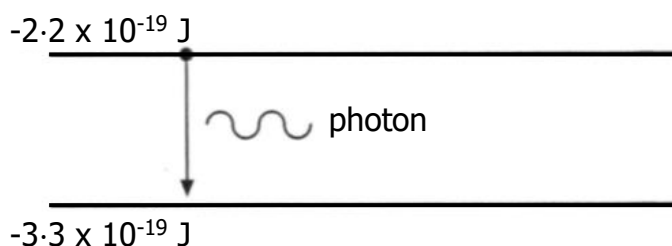

The energy in each pulse of radiation from the laser is 10 J. How many photons are there in each pulse?

- A  $1.8 \times 10^{19}$
- B  $3.0 \times 10^{19}$
- C  $3.7 \times 10^{19}$
- D  $4.5 \times 10^{19}$
- E  $9.1 \times 10^{19}$

3. An atom has the energy levels shown.

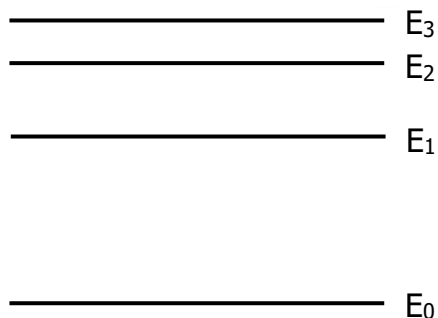

Electron transitions occur between all of the levels to produce emission lines in the spectrum of this atom.

How many emission lines are produced by transitions between these energy levels?

- A 3
  - B 4
  - C 5
  - D 6
  - E 7
4. The diagram shows some of the energy levels for the hydrogen atom.

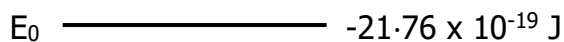
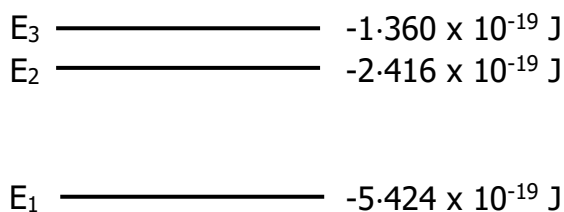

The highest frequency of radiation emitted due to a transition between two of these energy levels is

- A  $1.59 \times 10^{14}$  Hz
- B  $2.46 \times 10^{15}$  Hz
- C  $3.08 \times 10^{15}$  Hz
- D  $1.63 \times 10^{20}$  Hz
- E  $2.04 \times 10^{20}$  Hz.

5. The diagram represents some electron transitions between energy levels in an atom.

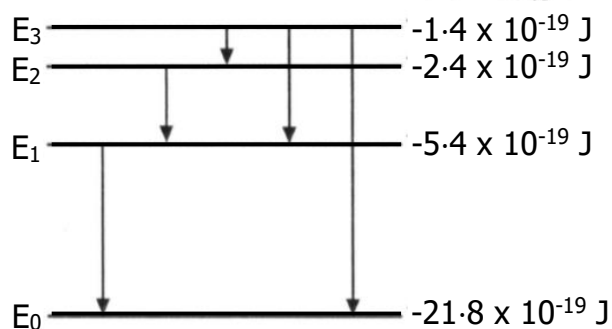

The radiation emitted with the shortest wavelength is produced by an electron making transition

- A  $E_1$  to  $E_0$   
 B  $E_2$  to  $E_1$   
 C  $E_3$  to  $E_2$   
 D  $E_3$  to  $E_1$   
 E  $E_3$  to  $E_0$ .
6. Part of the energy level diagram for an atom is shown.

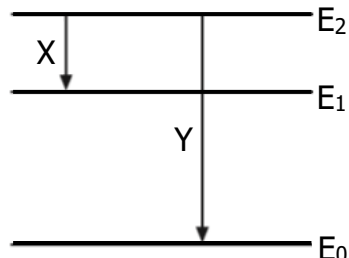

X and Y represent two possible electron transitions.

Which of the following statements is/are correct?

- I Transition Y produced photons of higher frequency than transition X.  
 II Transition X produces photons of longer wavelength than transition Y.  
 III When an electron is in the energy level  $E_0$ , the atom is ionised.
- A I only  
 B I and II only  
 C I and III only  
 D II and III only  
 E I, II and III

7. The diagram represents some of the energy levels for an atom of a gas.

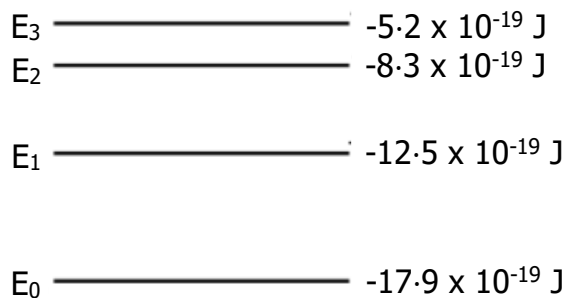

White light passes through the gas and absorption lines are observed in the spectrum.

Which electron transition produces the absorption line corresponding to the lowest frequency?

- A  $E_3$  to  $E_2$
  - B  $E_2$  to  $E_3$
  - C  $E_1$  to  $E_0$
  - D  $E_0$  to  $E_1$
  - E  $E_0$  to  $E_3$
8. In an atom, a photon of radiation is emitted when an electron makes a transition from a higher energy level to a lower energy level as shown.

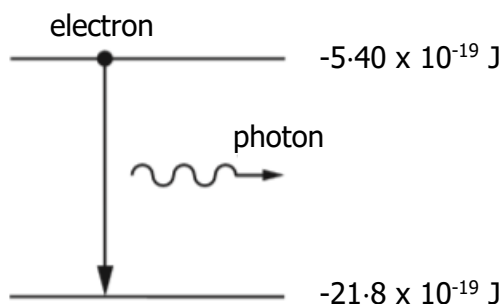

The wavelength of the radiation emitted due to an electron transition between the two energy levels shown is

- A  $1.2 \times 10^{-7} \text{ m}$
- B  $7.3 \times 10^{-8} \text{ m}$
- C  $8.2 \times 10^6 \text{ m}$
- D  $1.4 \times 10^7 \text{ m}$
- E  $2.5 \times 10^{15} \text{ m}$ .

9. When light passes through the outer layers of the Sun certain frequencies of light are absorbed by hydrogen atoms, producing dark lines in the spectrum.

The diagram represents some of the energy levels for a hydrogen atom.



The number of absorption lines in the spectrum caused by the transition of electrons between these energy levels is

- A 4
- B 6
- C 9
- D 10
- E 20.

10. Which graph shows the relationship between frequency  $f$  and wavelength  $\lambda$  of photons of electromagnetic radiation?

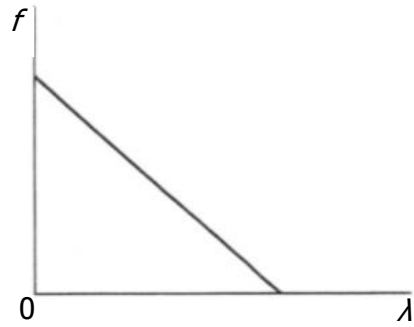
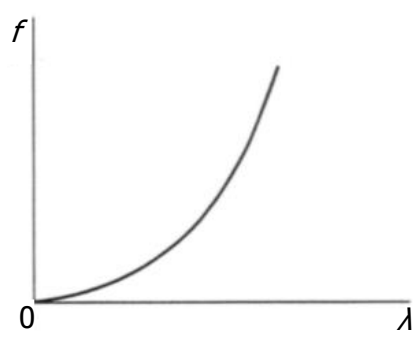
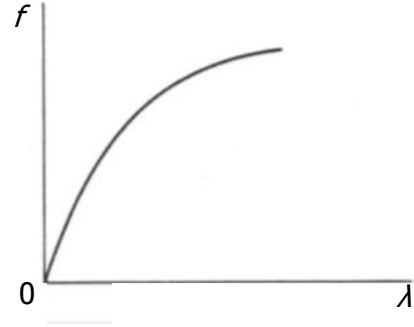
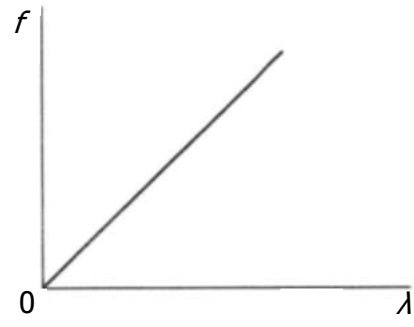
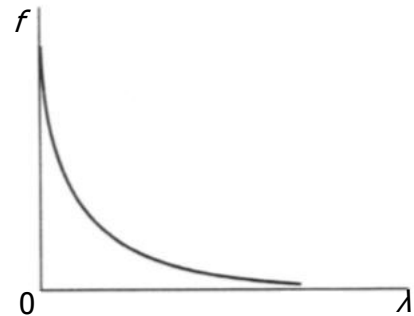



## Line Spectra

11. The following diagrams represent some of the energy levels for two different atoms **P** and **Q**. The diagrams are drawn to the same scale.

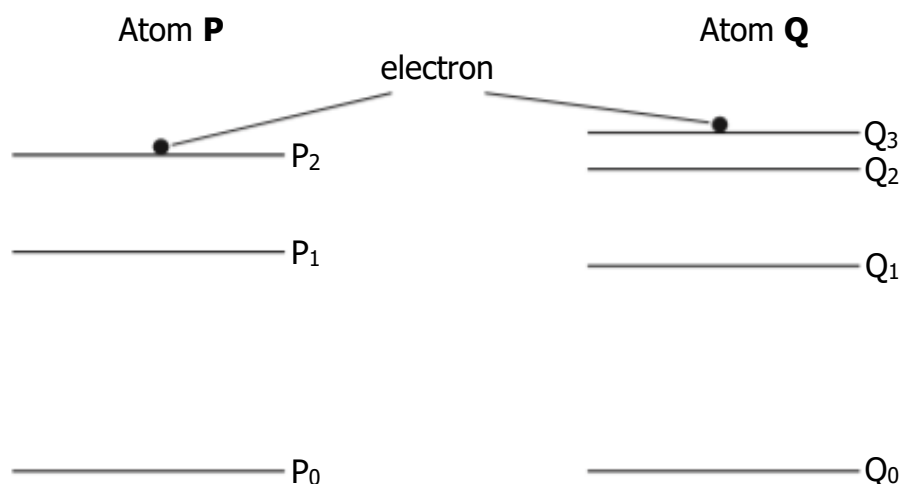

Electrons are continuously excited to levels  $P_2$  and  $Q_3$ .

When electrons make a transition to lower energy levels, photons of light are emitted.

The light is observed as various lines in the emission spectrum of each atom.

- (a) For atom **Q**, determine the number of lines in the emission spectrum for the energy levels shown. 1
- (b) Considering both atoms, identify the transition that produces radiation of the lowest frequency. 1
- (c) The table shows information about the energy levels in atom **P**.

<i>Energy Level</i>	<i>Energy / J</i>
$P_2$	$-2.4 \times 10^{-19}$
$P_1$	$-5.4 \times 10^{-19}$
$P_0$	$-21.8 \times 10^{-19}$

Calculate the shortest wavelength of radiation emitted from atom **P**. 4

- (d) The emission line due to the transition from  $P_2$  to  $P_1$  is the **same colour** as the emission line due to the transition from  $Q_2$  to  $Q_1$ .

Explain this observation. 1

## Line Spectra

12. The visible spectrum of light emitted by a star is observed to contain a number of dark lines. The dark lines occur because certain wavelengths of light are absorbed when light passes through atoms in the star's outer atmosphere.

The diagram shows some of the energy levels for a hydrogen atom.

$$E_3 \text{ ————— } -1.36 \times 10^{-19} \text{ J}$$

$$E_2 \text{ ————— } -2.42 \times 10^{-19} \text{ J}$$

$$E_1 \text{ ————— } -5.42 \times 10^{-19} \text{ J}$$

$$E_0 \text{ ————— } -21.8 \times 10^{-19} \text{ J}$$

- (a) For the energy levels shown in the diagram, identify the electron transition that would lead to the absorption of a photon with the highest frequency. 1
- (b) An electron makes the transition from energy level  $E_1$  to  $E_3$ .  
Determine the frequency of the photon absorbed. 3

## Line Spectra; Redshift

13. In a laboratory experiment, light from a hydrogen discharge lamp is used to produce a line emission spectrum. The line spectrum for hydrogen has four lines in the visible region as shown.



- (a) The production of the line spectrum can be explained using the Bohr model of the atom.

State **two** features of the *Bohr model* of the atom.

2

- (b) Some of the energy levels of the hydrogen atom are shown.

$$E_4 \text{ ————— } -0.871 \times 10^{-19} \text{ J}$$

$$E_3 \text{ ————— } -1.36 \times 10^{-19} \text{ J}$$

$$E_2 \text{ ————— } -2.42 \times 10^{-19} \text{ J}$$

$$E_1 \text{ ————— } -5.45 \times 10^{-19} \text{ J}$$

$$E_0 \text{ ————— } -21.8 \times 10^{-19} \text{ J}$$

One of the spectral lines is due to electron transitions from  $E_3$  to  $E_1$ .

Determine the frequency of the photon emitted when an electron makes this transition.

3

- (c) In the laboratory, a line in the hydrogen spectrum is observed at a wavelength of 656 nm.

When the spectrum of light from a distant galaxy is viewed, this hydrogen line is now observed at a wavelength of 661 nm.

Determine the recessional velocity of the distant galaxy.

5

## Line Spectra; Refraction

14. (a) Electrons which orbit the nucleus of an atom can be considered as occupying discrete energy levels.

The following diagram shows some of the energy levels for a particular atom.

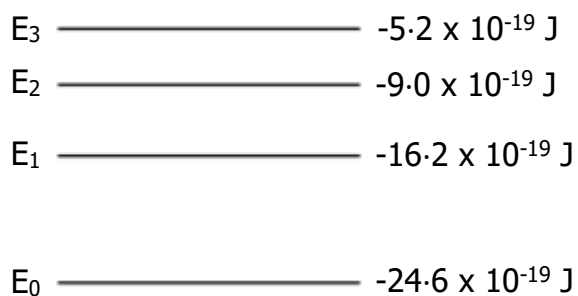

- (i) Radiation is produced when electrons make transitions from a higher to a lower energy level.

Identify which transition, between these energy levels, produces radiation with the shortest wavelength.

Justify your answer.

2

- (ii) An electron is excited from energy level  $E_2$  to  $E_3$  by absorbing light energy.

Determine the frequency of light used to excite this electron.

3

- (b) Another source of light has a frequency of  $4.6 \times 10^{14} \text{ Hz}$  in air.

A ray of this light is directed into a block of transparent material as shown.

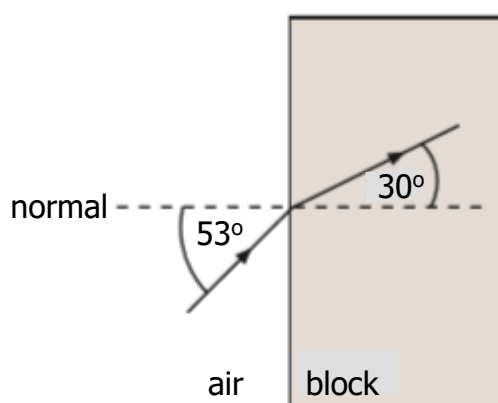

Calculate the wavelength of the light in the block.

4

## Line Spectra; Redshift

15. A binary star is a star system consisting of two stars orbiting around each other.

One of the techniques astronomers use to detect binary stars is to examine the spectrum of light emitted by the stars. In particular, they look for the changes in wavelength of a specific spectral line, called the hydrogen alpha line, over a period of time.

Accurate measurements of the wavelength of the hydrogen alpha line on Earth have determined it to be 656.28 nm.

- (a) The following diagram shows some of the energy levels for the hydrogen atom.

$E_4$	_____	$-1.36 \times 10^{-19} \text{ J}$
$E_3$	_____	$-2.42 \times 10^{-19} \text{ J}$
$E_2$	_____	$-5.45 \times 10^{-19} \text{ J}$
$E_1$	_____	$-21.8 \times 10^{-19} \text{ J}$

Radiation is emitted as photons when electrons make transitions from higher to lower energy levels.

Identify which transition, between these energy levels, produces the hydrogen alpha line.

Justify your answer by calculation.

4

15. **(continued)**

- (b) The graph shows how the wavelength of the hydrogen alpha line for one of the stars in a binary star system varies with time, as observed from Earth.

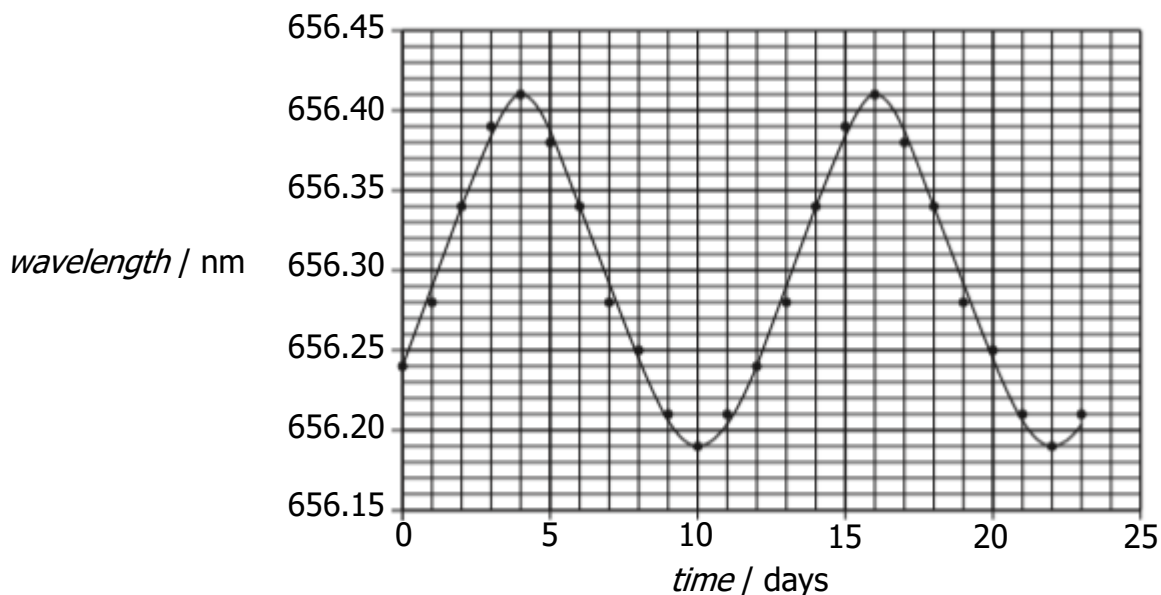

Using information from the graph:

- |       |   |          |
|-------|---|----------|
| (i)   | determine the period of orbit of this star;   | 1        |
| (ii)  | calculate the maximum recessional velocity of the star;   | <b>5</b> |
| (iii) | explain how the maximum approach velocity of the star compares to its maximum recessional velocity. | 2        |

## Line Spectra; Redshift

16. Light from the Sun is used to produce a visible spectrum.

A student views this spectrum and observes a number of dark lines as shown.

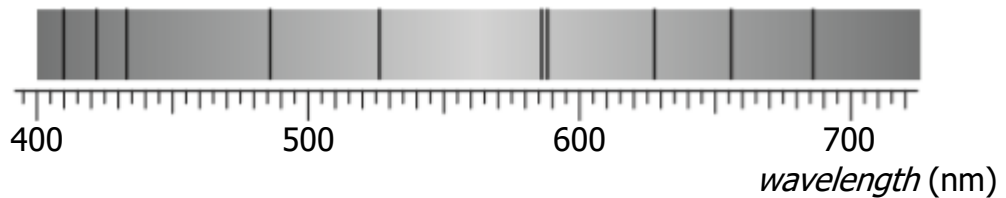

- (a) Explain how these dark lines in the spectrum of sunlight are produced. 2
- (b) One of the lines is due to hydrogen.

The position of this hydrogen line in the visible spectrum is shown for a distant galaxy, a nearby galaxy and the Sun.

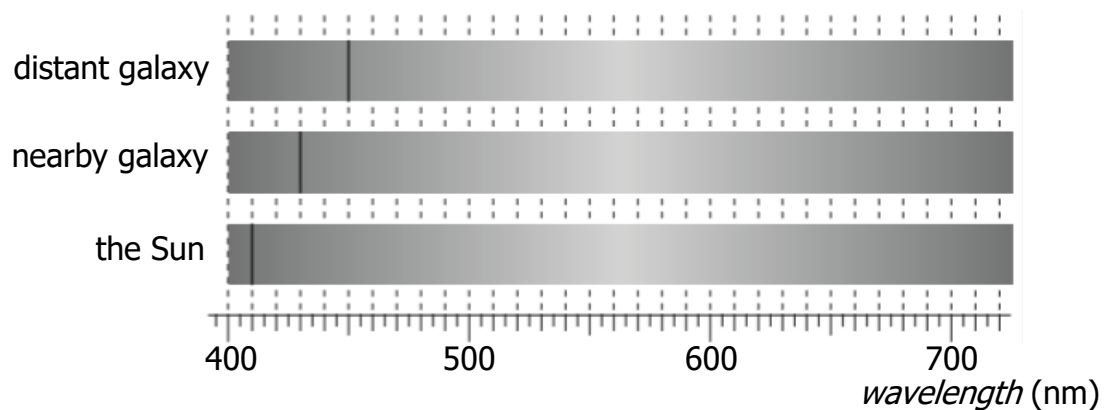

- (i) Explain why the position of the line is different in each of the spectra. 2
- (ii) Show that the redshift of the light from the distant galaxy is 0.098. 2
- (iii) Calculate the approximate distance to the distant galaxy. 5

Line Spectra; Irradiance

17. A laser emits light when electrons are stimulated to fall from a high energy level to a lower energy level.

The diagram shows some of the energy levels involved.

In one particular laser, a photon is produced by the electron transition from  $E_5$  to  $E_3$  as shown.

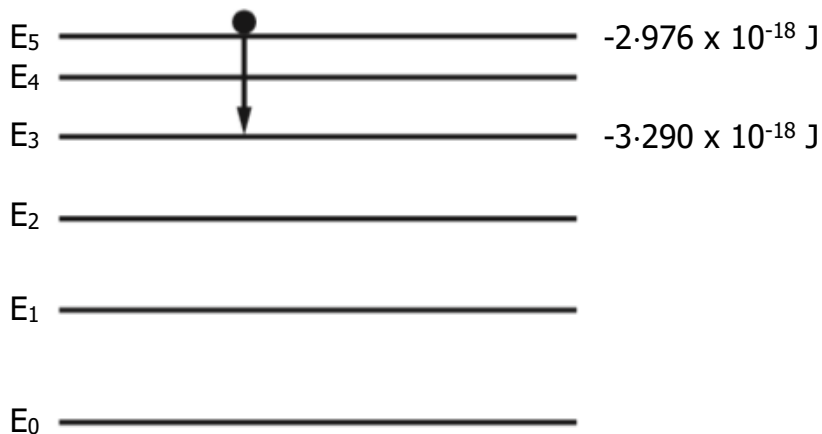

- (a) (i) Determine the wavelength of the photon emitted. 4  
 (ii) The laser beam is shown onto a screen. The beam produces a spot of diameter  $8.00 \times 10^{-4} \text{ m}$ .

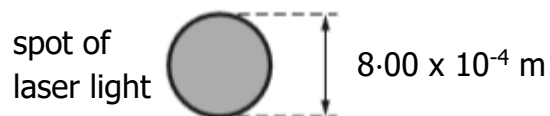

The irradiance of the spot of light on the screen is  $9950 \text{ W m}^{-2}$ .

Determine the power of the laser beam. 4

- (b) A student investigates how irradiance  $I$  varies with distance  $d$  from a point source of light, using the apparatus shown.

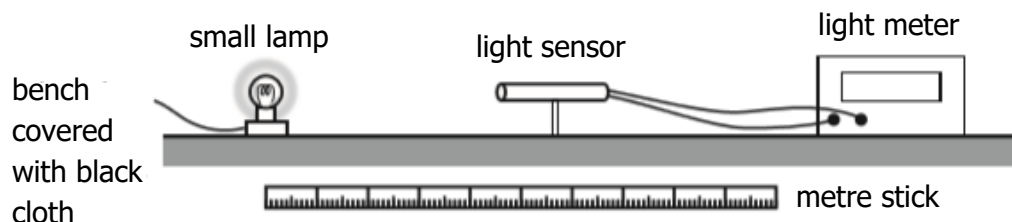

Describe how this apparatus could be used to verify the inverse square law for a point source of light. 3



## Refraction

1. The diagram below shows a ray of red light passing through a semi-circular block of glass.

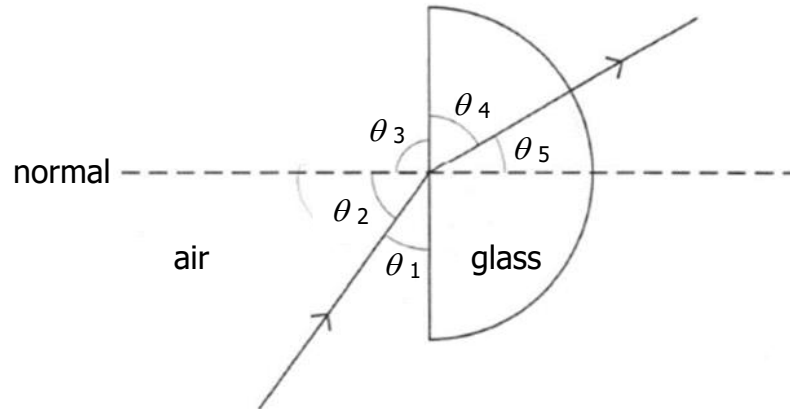

The refractive index of the glass for this light can be calculated from

- A  $\frac{\sin \theta_3}{\sin \theta_4}$
- B  $\frac{\sin \theta_1}{\sin \theta_4}$
- C  $\frac{\sin \theta_2}{\sin \theta_5}$
- D  $\frac{\sin \theta_2}{\sin \theta_4}$
- E  $\frac{\sin \theta_1}{\sin \theta_5}$
2. A ray of light passes from air into a substance that has a refractive index of 2.0. In air, the light has a wavelength  $\lambda$  and frequency  $f$ .

Which row in the following table gives the wavelength and frequency of the light in the substance?

	<i>Wavelength</i>	<i>Frequency</i>
A	$\lambda$	$f$
B	$\lambda/2$	$f/2$
C	$\lambda/2$	$f$
D	$2\lambda$	$2f$
E	$2\lambda$	$f$

3. Red light passes from air into water.

What happens to the speed and frequency of the light when it enters the water?

	<i>Speed</i>	<i>Frequency</i>
A	increases	increases
B	increases	stays constant
C	decreases	stays constant
D	decreases	decreases
E	stays constant	decreases

4. The spectrum of white light from a filament lamp may be viewed using a prism or grating.

A student, asked to compare the spectra formed by the two methods, made the following statements.

- I The prism produces a spectrum by refraction. The grating produces a spectrum by interference.
- II The spectrum formed by the prism shows all the wavelengths present in the white light. The spectrum formed by the grating shows only a few specific wavelengths.
- III The prism produces a single spectrum. The grating produces more than one spectrum.

Which of the above statements is/are true?

- A I only
- B II only
- C I and II only
- D I and III only
- E I, II and III

5. Light of frequency  $5.0 \times 10^{14}$  Hz passes from air into a block of glass of refractive index 1.5.

Which rock in the following table gives the correct values for the velocity, frequency and wavelength of the light in the glass?

	<i>velocity / m s<sup>-1</sup></i>	<i>frequency / Hz</i>	<i>wavelength / m</i>
A	$2.0 \times 10^8$	$5.0 \times 10^{14}$	$4.0 \times 10^{-7}$
B	$3.0 \times 10^8$	$5.0 \times 10^{14}$	$6.0 \times 10^{-7}$
C	$3.0 \times 10^8$	$3.3 \times 10^{14}$	$6.0 \times 10^{-7}$
D	$2.0 \times 10^8$	$3.3 \times 10^{14}$	$6.0 \times 10^{-7}$
E	$3.0 \times 10^8$	$3.3 \times 10^{14}$	$4.0 \times 10^{-7}$

6. A liquid and a solid have the same refractive index.

What happens to the speed and the wavelength of light passing from the liquid into the solid?

	<i>Speed</i>	<i>Wavelength</i>
A	stays the same	stays the same
B	decreases	decreases
C	decreases	increases
D	increases	increases
E	increases	decreases

7. Microwaves of frequency  $2.0 \times 10^{10}$  Hz travel through air with a speed of  $3.0 \times 10^8$  m s<sup>-1</sup>. On entering a bath of oil, the speed reduces to  $1.5 \times 10^8$  m s<sup>-1</sup>.

The frequency of the microwaves in the oil is

- A  $1.0 \times 10^{10}$  Hz
- B  $2.0 \times 10^{10}$  Hz
- C  $4.0 \times 10^{10}$  Hz
- D  $3.0 \times 10^{18}$  Hz
- E  $6.0 \times 10^{18}$  Hz.

8. Light travels from glass into air.

Which row in the table describes what happens to the speed, frequency and wavelength of the light?

	<i>Speed</i>	<i>Frequency</i>	<i>Wavelength</i>
A	increases	stays constant	increases
B	increases	decreases	stays constant
C	stays constant	decreases	decreases
D	decreases	decreases	stays constant
E	decreases	stays constant	decreases

9. The diagram represents a ray of light passing from air into liquid.

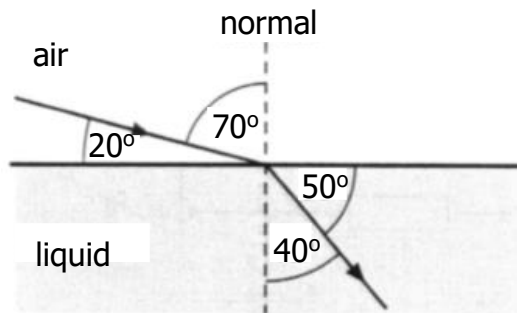

The refractive index of this liquid, relative to the air, is

- A  $\frac{\sin 20^\circ}{\sin 40^\circ}$
- B  $\frac{\sin 40^\circ}{\sin 70^\circ}$
- C  $\frac{\sin 50^\circ}{\sin 20^\circ}$
- D  $\frac{\sin 70^\circ}{\sin 40^\circ}$
- E  $\frac{\sin 90^\circ}{\sin 40^\circ}$

10. A beam of white light is passed through two optical components P and Q. Component P produces a number of spectra and component Q produces a spectrum as shown.

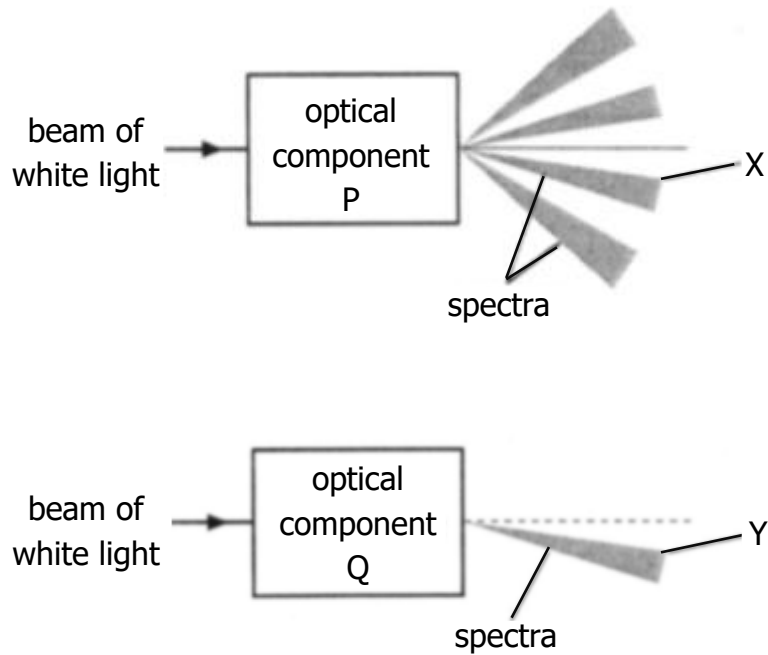

Which row in the table identifies the optical components and the colour of light seen at position X and Y?

	<i>Optical component P</i>	<i>Colour seen at X</i>	<i>Optical component Q</i>	<i>Colour seen at Y</i>
A	grating	red	triangular prism	red
B	grating	red	triangular prism	violet
C	grating	violet	triangular prism	red
D	triangular prism	red	grating	violet
E	triangular prism	violet	grating	red

11. A ray of light travels from air into a glass prism. The refractive index of the glass is 1.50.

Which diagram shows the correct path of the ray?

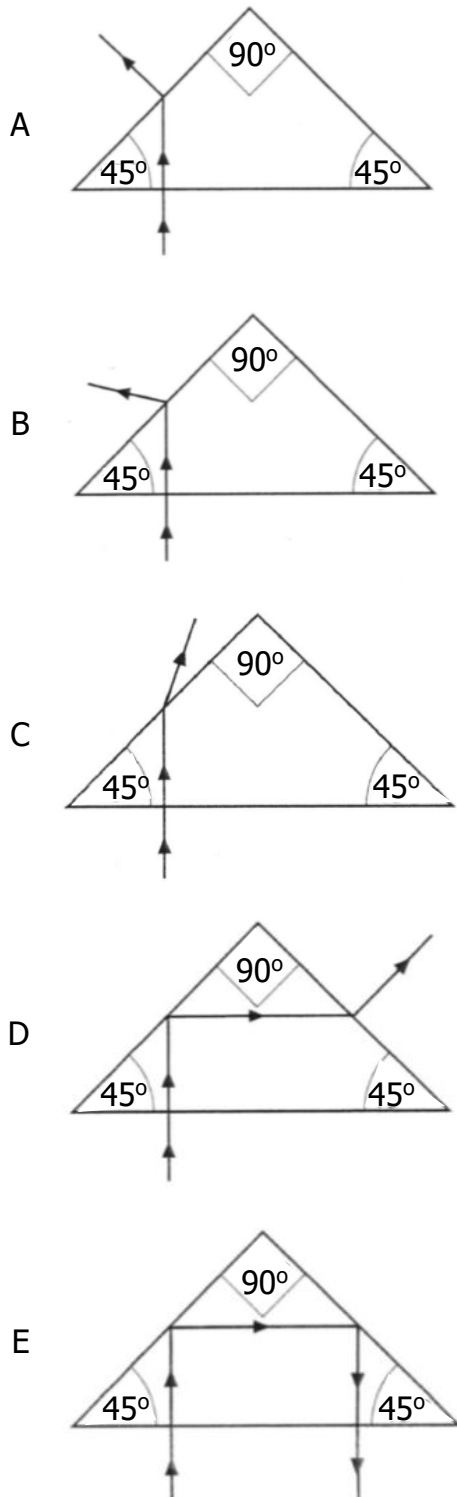

12. The value of the absolute refractive index of diamond is 2.42.  
The critical angle for diamond is

- A  $0.413^\circ$
  - B  $24.4^\circ$
  - C  $42.0^\circ$
  - D  $65.6^\circ$
  - E  $90.0^\circ$ .
13. A ray of monochromatic light passes into a glass block as shown.

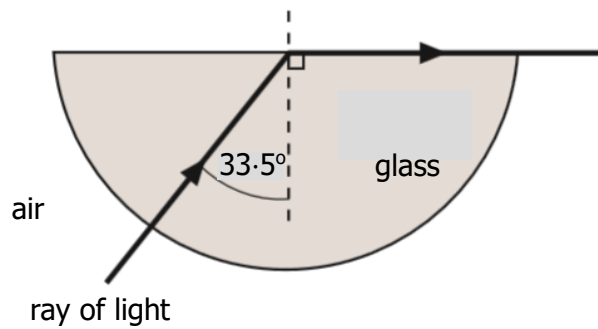

The refractive index of the glass for this light is

- A 0.03
- B 0.55
- C 0.87
- D 1.20
- E 1.81.

14. A prism is used to produce a spectrum from a source of white light as shown.

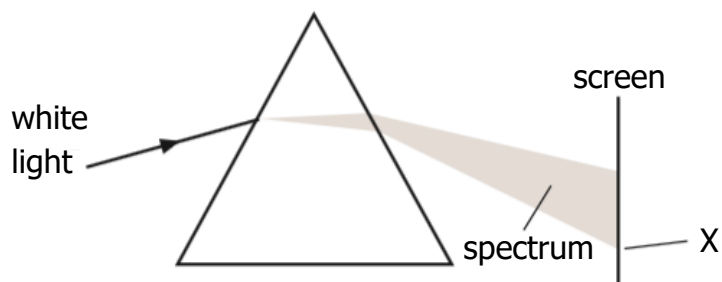

The colour observed at X is noted.

The prism is then replaced by a grating to produce spectra as shown.

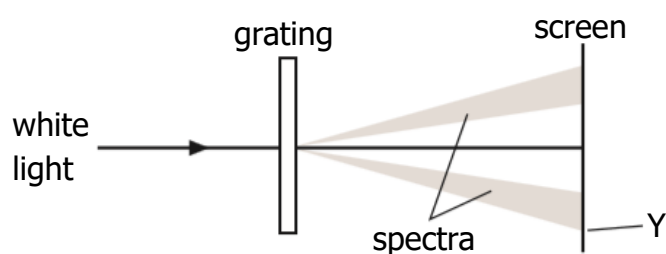

The colour observed at Y is noted.

Which row in the table gives the colour and wavelength of the light observed at X and the light observed at Y?

<i>Colour of light at X</i>	<i>Wavelength of light at X (nm)</i>	<i>Colour of light at Y</i>	<i>Wavelength of light at Y (nm)</i>
Red	450	Red	450
Blue	450	Blue	450
Blue	650	Red	450
Blue	450	Red	650
Red	650	Blue	450



15. The diagram shows the path of a ray of red light as it passes from air into substance X.

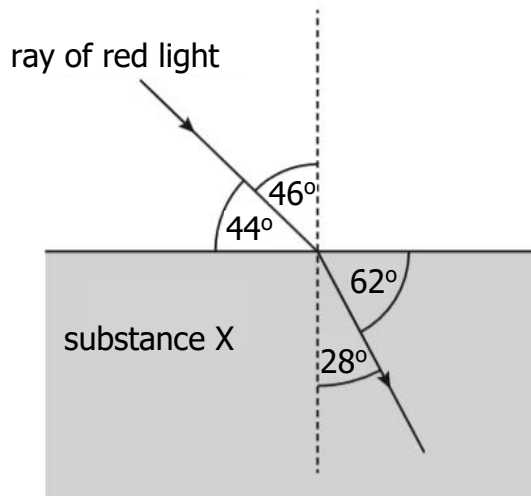

The critical angle for the light in substance X is

- A  $32^\circ$   
 B  $41^\circ$   
 C  $45^\circ$   
 D  $52^\circ$   
 E  $90^\circ$ .
16. An optical fibre consists of a glass core surrounded by cladding made of different glass. A ray of red light travels through the optical fibre as shown.

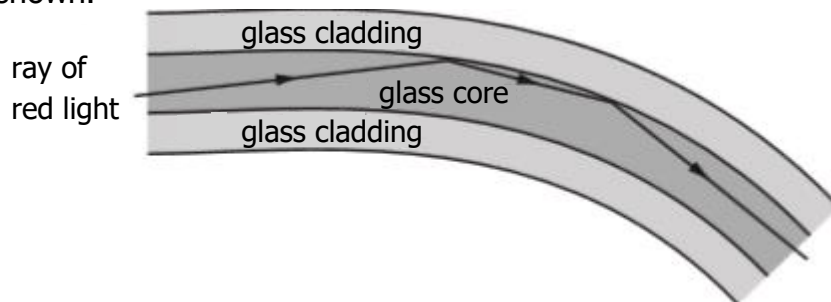

The red light travels as shown because

- A the speed of light in the core is greater than the speed of light in the cladding  
 B the refractive index of the core is greater than the refractive index of the cladding  
 C the refractive index of the core is less than the refractive index of the cladding  
 D the frequency of light in the core is greater than the frequency of light in the cladding  
 E the frequency of light in the core is less than the frequency of light in the cladding.

17. Red light is used to investigate the critical angle of two materials P and Q.

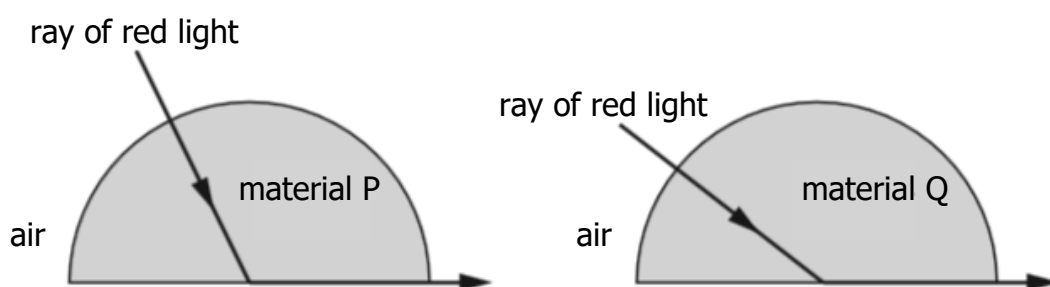

A student makes the following statements.

- I Material P has a higher refractive index than material Q.
- II The wavelength of the red light is longer inside material P than inside material Q.
- III The red light travels at the same speed inside materials P and Q.

Which of these statements is/are correct?

- A I only
  - B II only
  - C III only
  - D I and II only
  - E I, II and III
18. Light travels from water into air.

Which row in the table describes what happens to the speed, frequency and wavelength of the light?

	<i>Speed</i>	<i>Frequency</i>	<i>Wavelength</i>
A	decreases	stays constant	decreases
B	decreases	increases	stays constant
C	stays constant	increases	increases
D	increases	increases	stays constant
E	increases	stays constant	increases

19. A ray of blue light passes from air into a transparent block as shown.

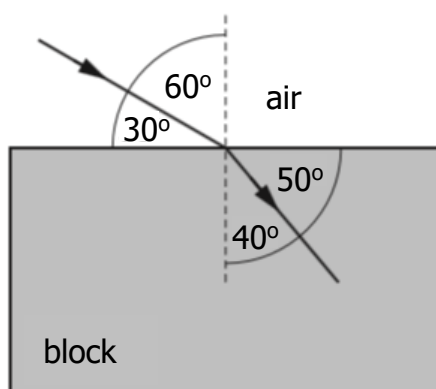

The speed of this light in the block is

- A  $1.80 \times 10^8 \text{ m s}^{-1}$   
 B  $1.96 \times 10^8 \text{ m s}^{-1}$   
 C  $2.00 \times 10^8 \text{ m s}^{-1}$   
 D  $2.23 \times 10^8 \text{ m s}^{-1}$   
 E  $2.65 \times 10^8 \text{ m s}^{-1}$
20. A ray of red light passes from a liquid to a transparent solid.  
 The solid and the liquid have the same refractive index for this light.  
 Which row in the table shows what happens to the speed and frequency of the light as it passes from the liquid into the solid?

	<i>Speed</i>	<i>Frequency</i>
A	decreases	decreases
B	decreases	increases
C	no change	increases
D	increases	no change
E	no change	no change

21. A ray of monochromatic light passes from air into a block of glass as shown.

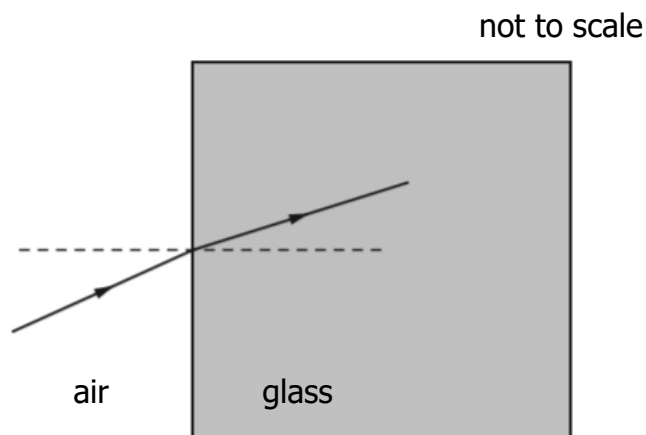

The wavelength of this light in air is  $6.30 \times 10^{-7}$  m.

The refractive index of the glass for this light is 1.50.

The frequency of this light in the glass is

- A  $2.10 \times 10^{-15}$  Hz
  - B  $1.26 \times 10^2$  Hz
  - C  $1.89 \times 10^2$  Hz
  - D  $4.76 \times 10^{14}$  Hz
  - E  $7.14 \times 10^{14}$  Hz.
22. A ray of monochromatic light passes from air into water.

The wavelength of this light in air is 589 nm.

The speed of this light in water is

- A  $2.56 \times 10^2$  m s<sup>-1</sup>
- B  $4.52 \times 10^2$  m s<sup>-1</sup>
- C  $2.26 \times 10^8$  m s<sup>-1</sup>
- D  $3.00 \times 10^8$  m s<sup>-1</sup>
- E  $3.99 \times 10^8$  m s<sup>-1</sup>.

Interference and Diffraction Gratings; Refraction

23. (a) Light of wavelength  $486 \times 10^{-9}$  m is viewed using a grating with a slit spacing of  $2.16 \times 10^{-6}$  m.

Calculate the angle between the central maximum and the second order maximum.

3

- (b) A ray of monochromatic light passes from air into a block of glass as shown.

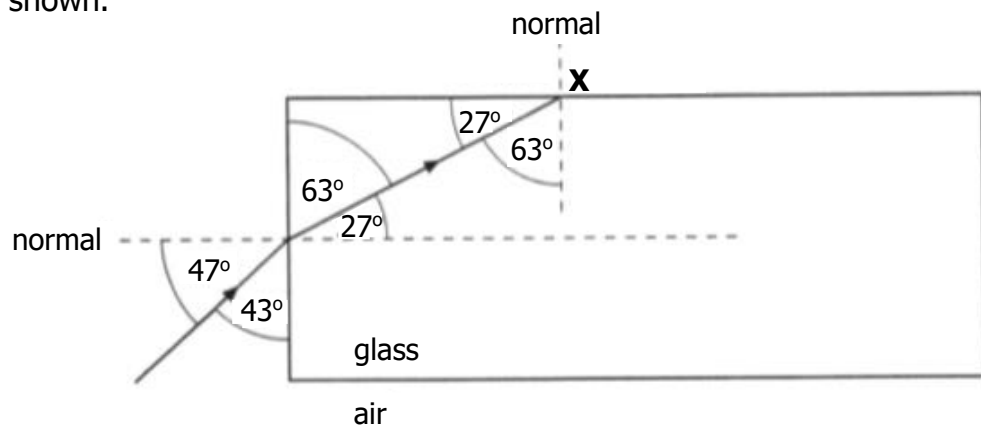

- (i) Using information from the diagram, show that the refractive index of the glass for this light is 1.61.
- (ii) State whether the ray is totally internally reflected at point **X**.

2

You must justify your answer by calculation.

2

## Refraction

24. A ray of red light is directed at a glass prism of side 80 mm as shown in the diagram below.

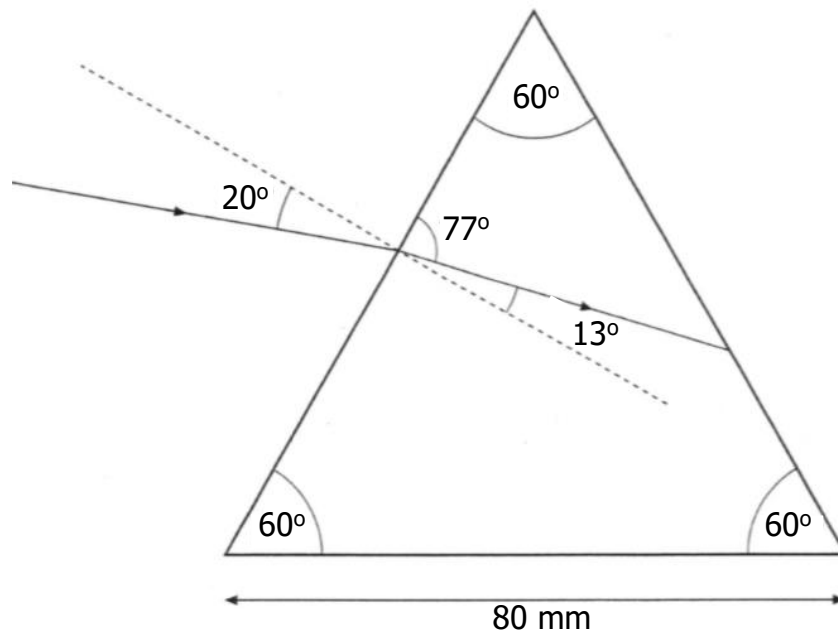

- (a) Using information from this diagram, show that the refractive index of the glass for this red light is 1.52. 2
- (b) State what is meant by the term *critical angle*. 1
- (c) Calculate the critical angle for the red light in the prism. 3
- (d) Copy in the diagram shown then complete the diagram to show the path of the red light as it passes through the prism and emerges into the air. 4
- Mark on your diagram the values of all relevant angles.

## Refraction

25. A decorative lamp has a transparent liquid in the space above a bulb. Light from the bulb passes through rotating coloured filters giving red or blue light in the liquid.

(a) A ray of red light is incident on the liquid surface as shown.

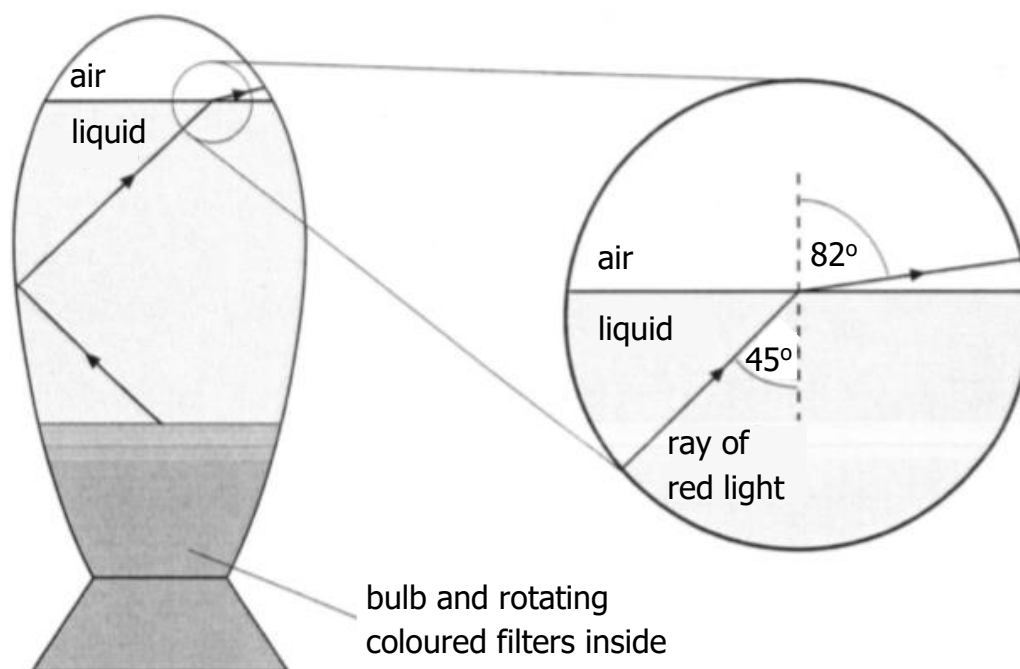

- (i) Calculate the refractive index of the liquid for the red light. 3
- (ii) A ray of blue light is incident on the liquid surface at the same angle as the ray of red light.

The refractive index of the liquid for blue light is greater than that for red light.

State whether the angle of refraction is greater than, equal to or less than  $82^\circ$  for the blue light.

You must explain your answer. 2

- (b) A similar lamp contains a liquid which has a refractive index of 1.44 for red light. A ray of red light in the liquid is incident on the surface at an angle of  $45^\circ$  as before.

State whether the ray of red light will refract out at the surface or totally internally reflect.

You must justify your answer by calculation. 2

Refraction; Interference and Diffraction Gratings

26. A physics student investigates what happens when monochromatic light passes through a glass prism or a grating.

(a) The apparatus for the first experiment is shown below.

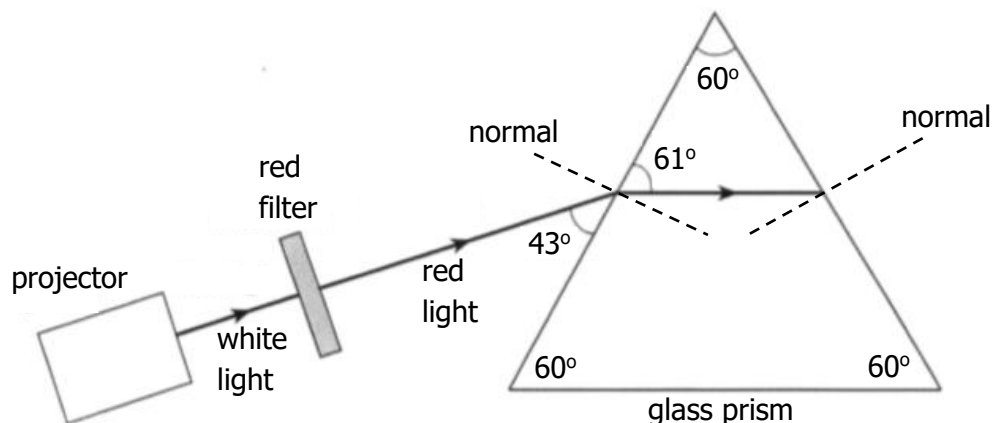

- (i) Calculate the refractive index of the glass for the red light. 3
  - (ii) Calculate the critical angle of the glass for the red light. 3
  - (iii) Sketch a diagram which shows the ray of red light before, during and after passing through the prism. 4
- Mark on your diagram the values of all relevant angles.

(b) The apparatus for the second experiment is shown below.

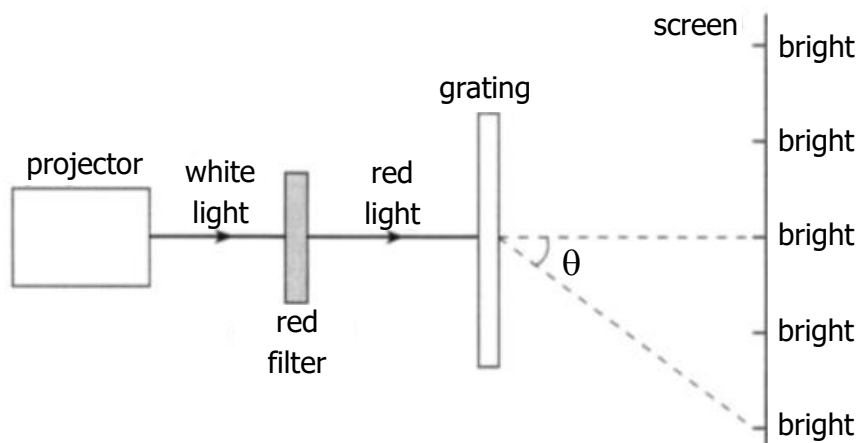

A pattern of bright and dark fringes is observed in the screen.

The grating has 300 lines per millimetre and the wavelength of the red light is 650 nm.

- (i) Explain how the bright fringes are produced. 1
- (ii) Calculate the angle  $\theta$  of the second order maximum. 3
- (iii) The red filter is replaced by a blue filter so that a blue ray of light is incident on the grating. Describe the effect of this change on the pattern observed. Justify your answer. 2



## Refraction

27. A ray of red light is incident on a semicircular block of glass at the mid-point of XY as shown.

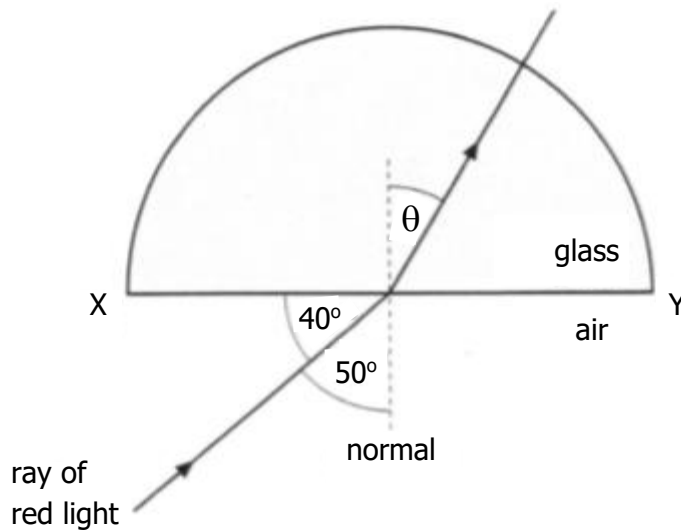

The refractive index of the block is 1.50 for this red light.

- (a) Calculate angle  $\theta$  shown on the diagram. 3
- (b) The wavelength of the red light **in the glass** is 420 nm.  
Calculate the wavelength of the light in air. 3
- (c) The ray of red light is replaced by a ray of blue light incident at the same angle. The blue light enters the block at the same point.

State whether the angle of refraction inside the glass is greater than, less than or equal to the angle  $\theta$  you calculated in question (a).

You must justify your answer. 2

Refraction

28. (a) A ray of red light of frequency  $4.80 \times 10^{14}$  Hz is incident on a glass lens as shown.

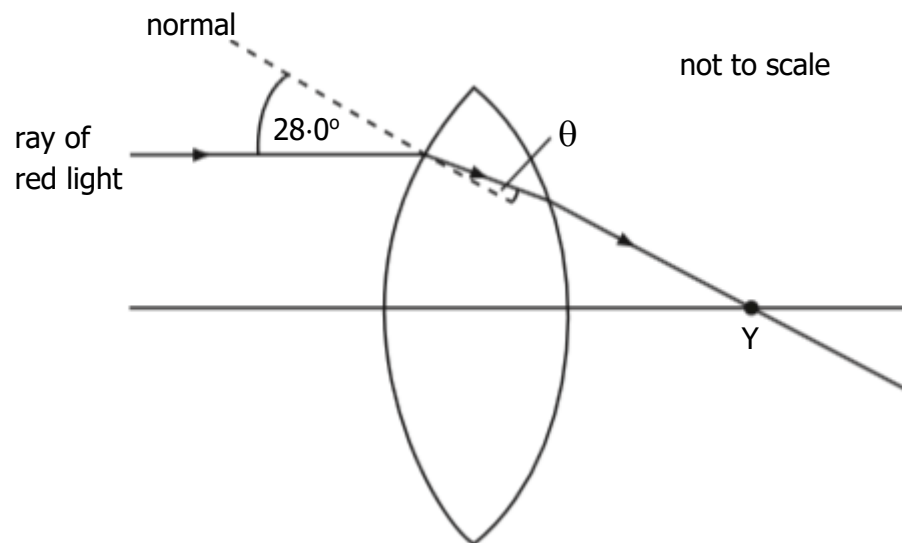

The ray passes through point Y after leaving the lens.

The refractive index of the glass is 1.61 for this red light.

- (i) Calculate the value of the angle  $\theta$  shown in the diagram. 3
- (ii) Calculate the wavelength of this light inside the lens. 4
- (b) The ray of red light is now replaced by a ray of blue light.  
The ray is incident on the lens at the same point as in part (a).

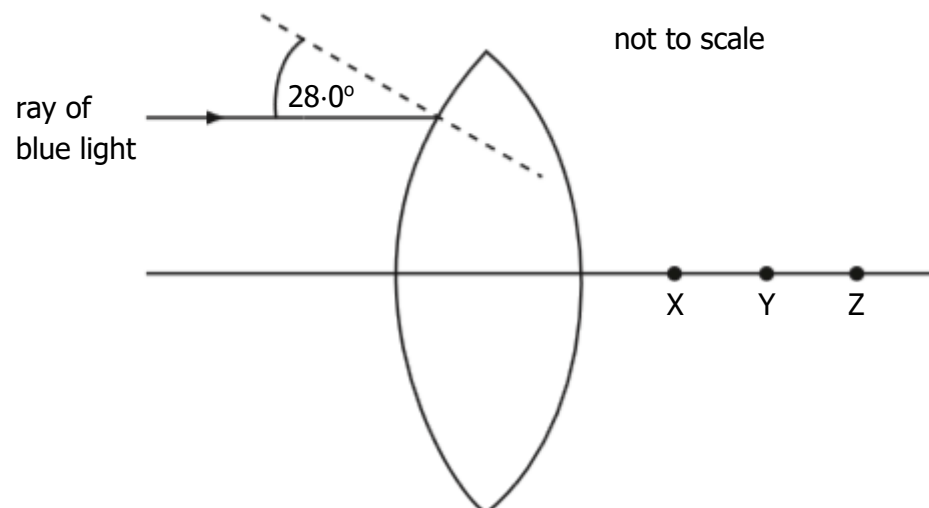

State which point, X, Y or Z, this ray pass through after leaving the lens.

You must justify your answer.

2

## Refraction

29. A garden spray consists of a tank, a pump and a spray nozzle.



A gardener observes a spectrum when sunlight illuminates the drops of water in the spray. This is because each drop of water is acting as a prism.

The diagram below shows the path taken by light of wavelength 650 nm through a drop of water.

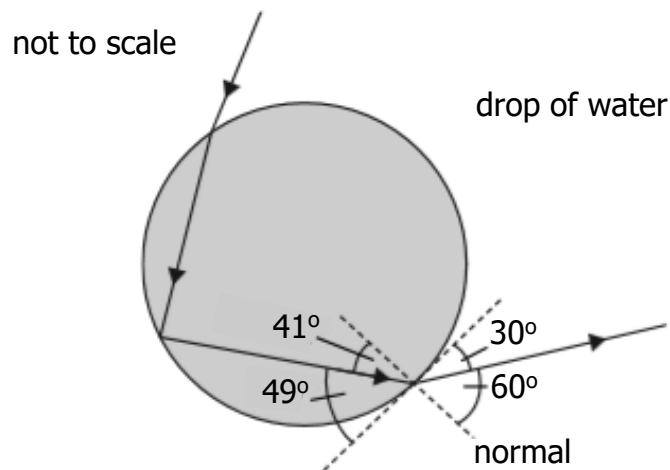

- (a) State what happens to the frequency of this light when it enters the drop of water. 1
- (b) Using information from the diagram, calculate the refractive index of the water for this wavelength of light. 3
- (c) Calculate the critical angle for this wavelength of light in the water. 3
- (d) Light of shorter wavelength also passes through the drop of water.

State whether the critical angle for this light will be less than, equal to, or greater than that for light of wavelength 650 nm.

Justify your answer.

2

Refraction

30. (a) A ray of red light is incident on a block of glass as shown. At surface **PQ** some of the light refracts out and some of it internally reflects.

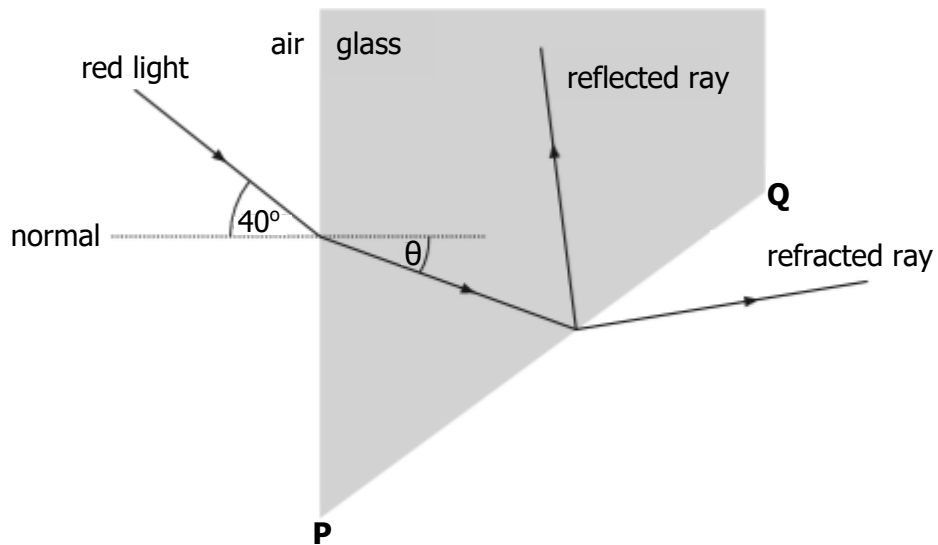

The refractive index of the glass for this light is 1.66.

- (i) Calculate the value of the angle  $\theta$  shown in the diagram. 3  
 (ii) The direction of the incident light ray is now changed so that the refracted ray emerges along face **PQ** as shown.

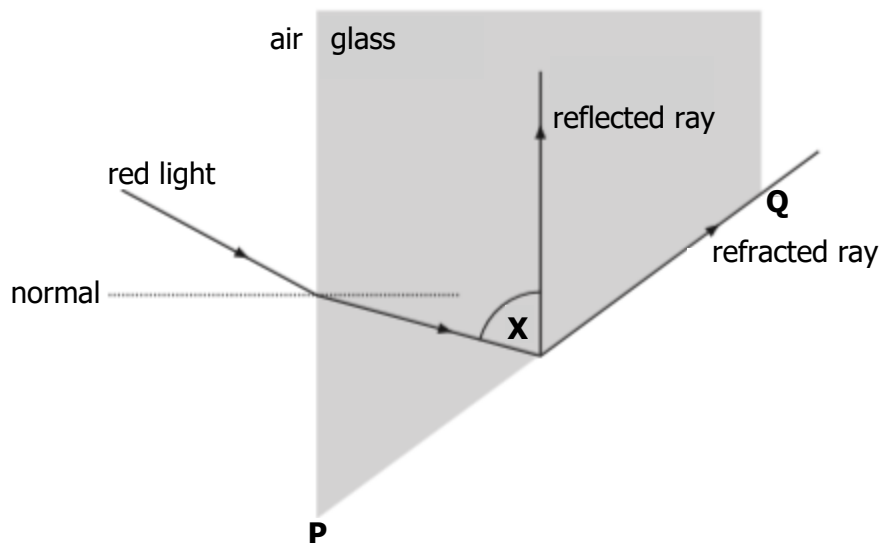

- (A) Calculate the critical angle for the red light in this glass. 3  
 (B) Determine the size of angle **X** shown in the diagram. 1
- (b) The ray of red light is now replaced with a ray of blue light.  
 This ray of blue light is directed towards the block along the same path as the ray of red light in part (a)(ii).  
 State whether or not the blue light is refracted at **PQ**. 2  
 You must justify your answer. 2

## Refraction

31. A technician investigates the path of laser light as it passes through a glass tank filled with water. The light enters the glass tank along the normal at **C** then reflects off a mirror submerged in the water. Some of the light is refracted at the surface of the water and some is reflected.

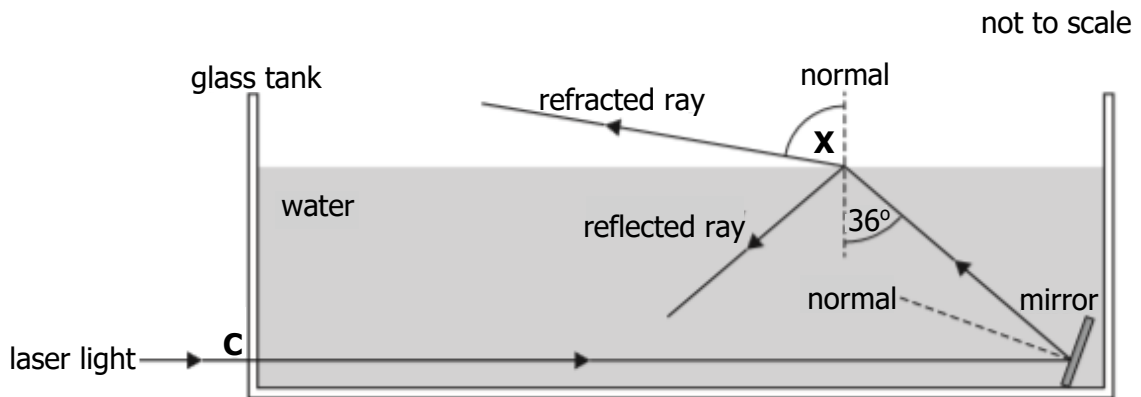

The refractive index of water for this laser light is 1.33.

- (a) Calculate angle **X**. 3
- (b) The mirror is now adjusted until the light follows the paths shown.

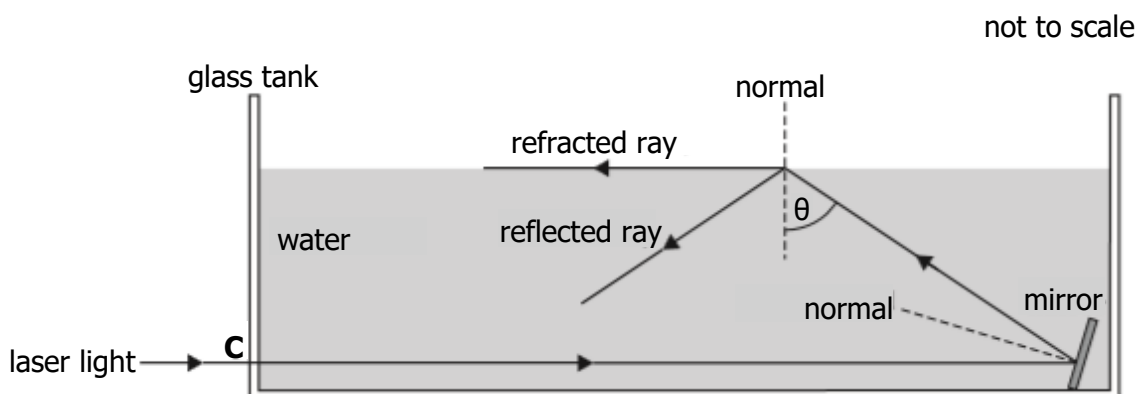

- (i) Explain why the value of  $\theta$  is equal to the critical angle for this laser light in water. 1
- (ii) Calculate angle  $\theta$ . 3
- (c) The water is now replaced with a liquid which has a greater refractive index. The mirror is kept at the same angle as in part (b) and the incident ray again enters the tank along the normal at **C**.

Draw a sketch which shows the path of the light ray **after** it has reflected off the mirror.

Your sketch should show what happens at the surface of the liquid. 1

## Refraction

32. A student places a glass paper weight containing air bubbles on a sheet of white paper.



The student notices that when white light passes through the paperweight, a pattern of spectra is produced.

The student decides to study this effect in more detail by carrying out an experiment in the laboratory.

A ray of green light follows the path shown as it enters an air bubble inside glass.

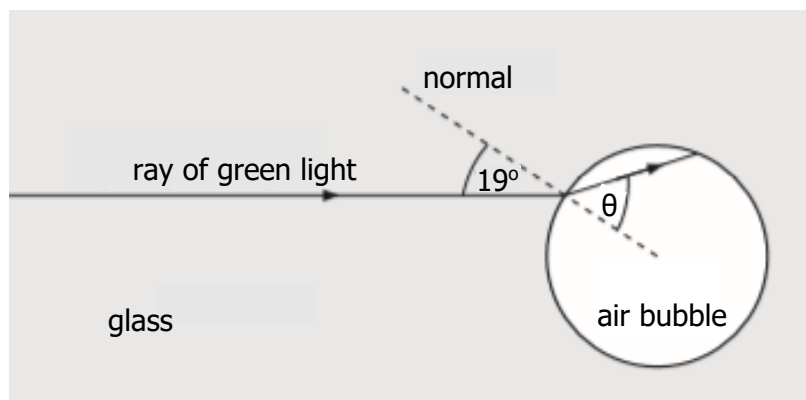

not to scale

The refractive index of the glass for this light is 1.49.

- (a) Calculate the angle of refraction,  $\theta$ , inside the air bubble. 3
- (b) Calculate the maximum angle of incidence at which a ray of green light can enter the air bubble. 3
- (c) The student now replaces the ray of green light with a ray of white light. Explain, in terms of refraction, why a spectrum is produced. 1

## Refraction

33. Monochromatic light is shone into a triangular prism of flint glass.

The graph shows how the refractive index of flint glass varies with the wavelength of light in air.

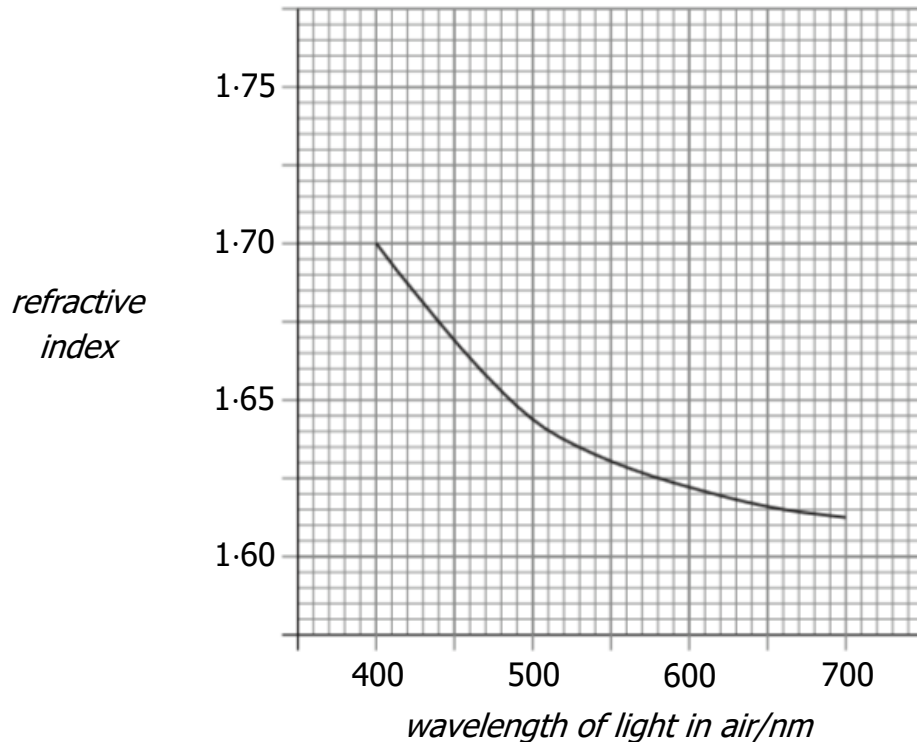

- (a) A ray of monochromatic light of wavelength 660 nm in air passes through the prism as shown.

not to scale

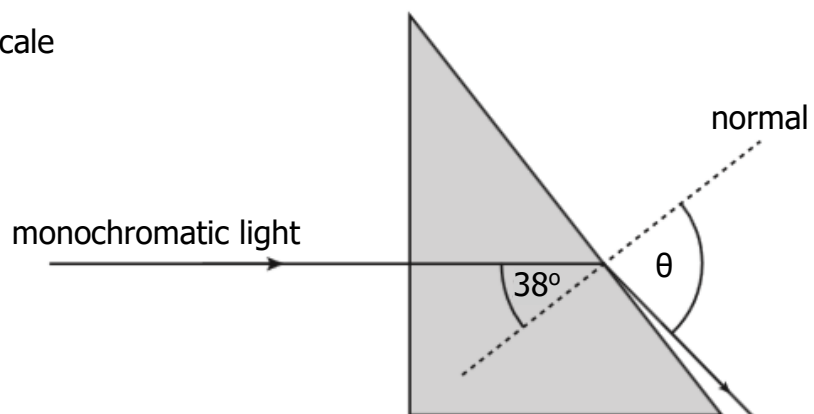

Calculate the angle of refraction  $\theta$ .

3

- (b) The ray of light is now replaced with one of shorter wavelength.

State whether the speed of this new ray in the prism is less than, the same as or greater than the speed of the 660 nm ray in the prism.

Justify your answer.

2

## Refraction; Interference and Diffraction Gratings

34. A student carries out two experiments to investigate the spectra produced from a ray of white light.
- (a) In the first experiment, a ray of white light is incident on a glass prism as shown.

**not to scale**

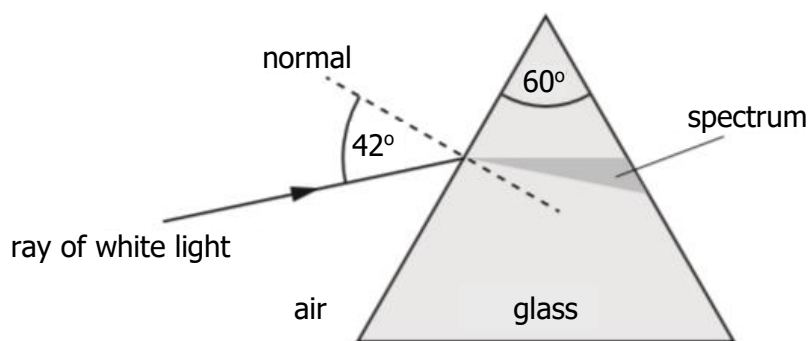

- (i) Explain why a spectrum is produced in the glass prism. 1
- (ii) The refractive index of the glass for red light is 1.54.  
Calculate the speed of red light in the glass prism. 3
- (b) In the second experiment, a ray of white light is incident on a grating.

**not to scale**

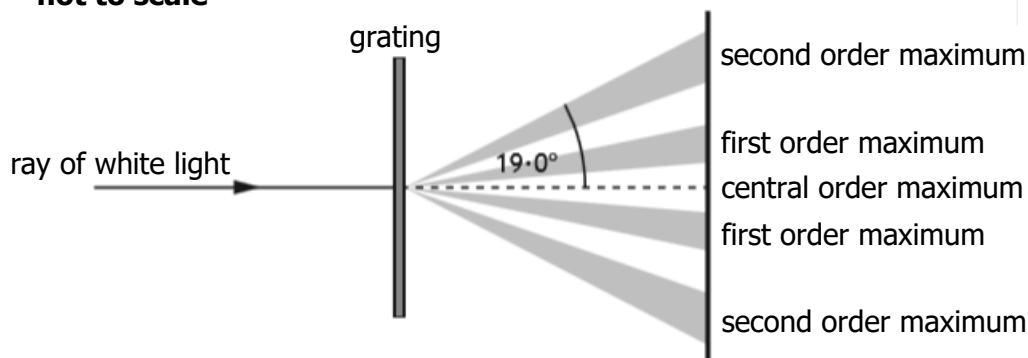

The angle between the central maximum and the second order maximum for red light is  $19.0^\circ$ .

The frequency of this red light is  $4.57 \times 10^{14}$  Hz.

- (i) Calculate the distance between slits on this grating. 4
- (ii) Explain why the angle of the second order maximum for blue light is different to that for red light. 2



## Refraction

35. Retroflective materials reflect light to enhance the visibility of clothing.



One type of retroflective material is made from small glass spheres partially embedded in a silver-coloured surface that reflects light.

A ray of monochromatic light follows the path shown as it enters one of the glass spheres.

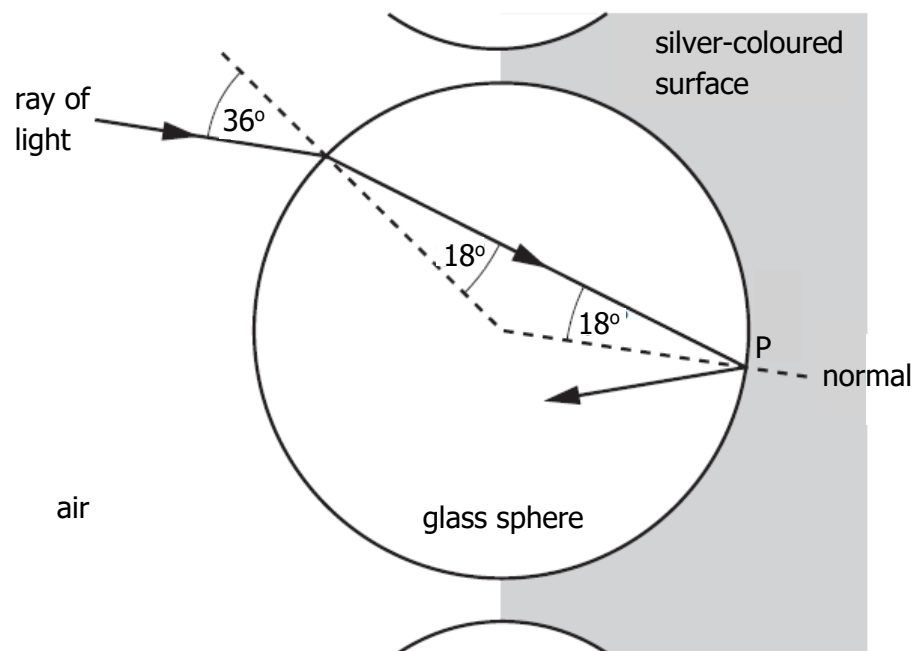

- (a) State what is meant by the term *refractive index* of a medium. 1
- (b) Calculate the refractive index of the glass for this light. 3
- (c) Calculate the critical angle for this light in the glass. 3

Refraction

36. A ray of monochromatic light is incident on a glass prism as shown.

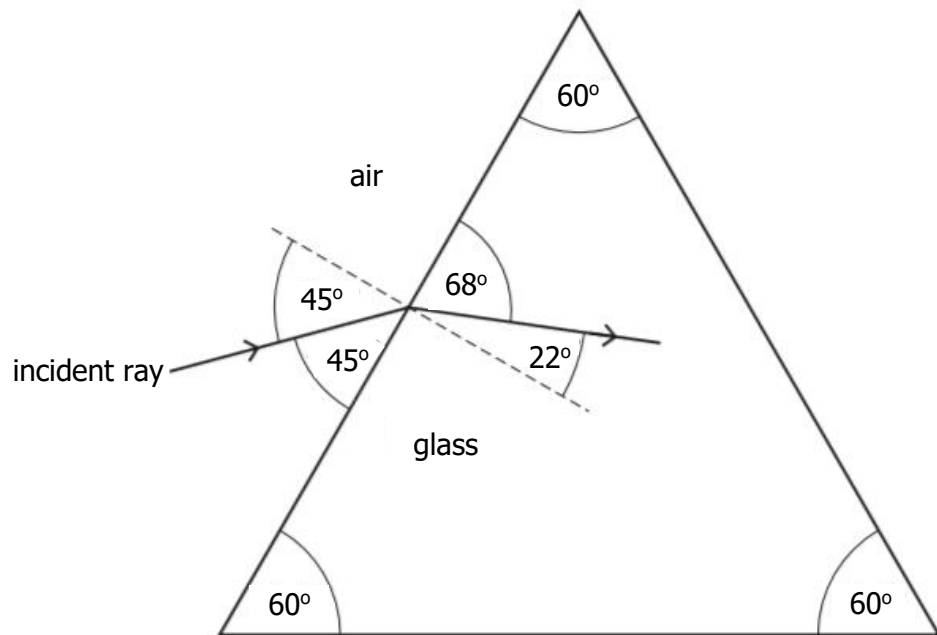

- (a) Show that the refractive index of the glass for this ray of light is 1.89. 2
- (b) (i) State what is meant by the term *critical angle*. 1
- (ii) Calculate the critical angle for this light in the prism. 3
- (iii) Copy and complete the diagram below to show the path of the ray as it passes through the prism and emerges into the air. 4

Mark on the diagram the values of all relevant angles.

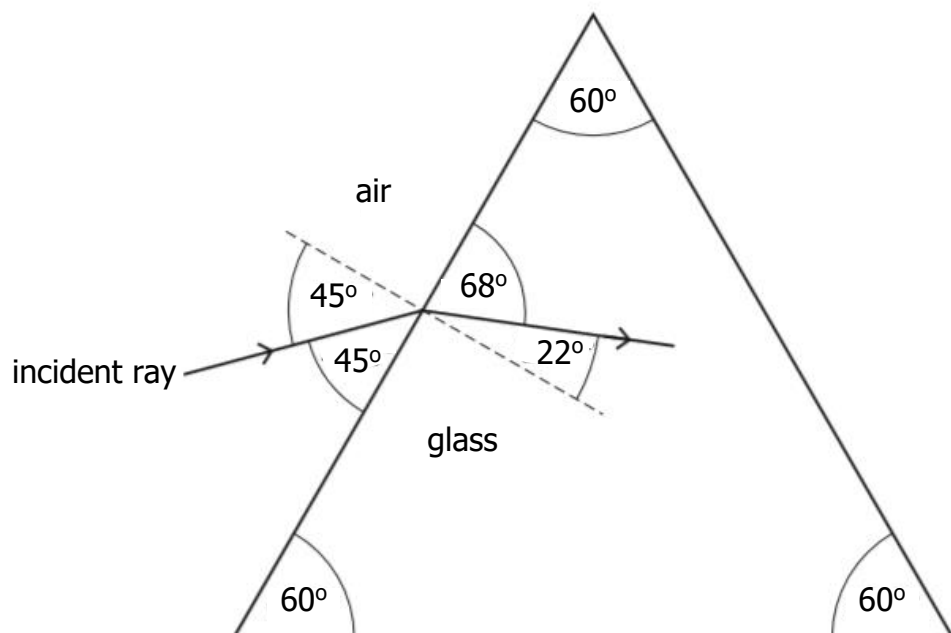

## Refraction

37. Diamonds sparkle because light that enters the diamond is reflected back to an observer.

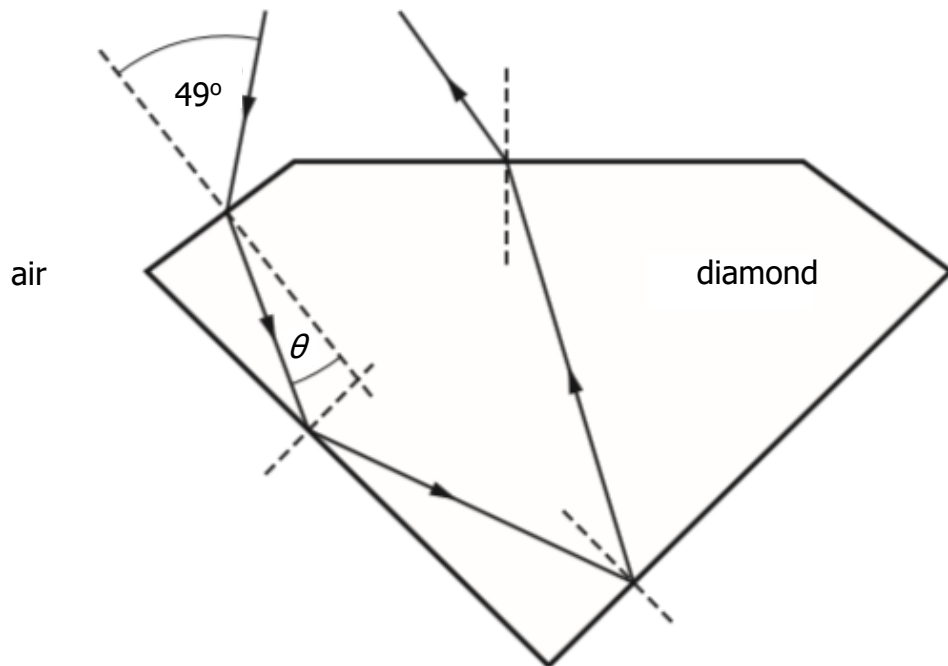

- (a) A ray of monochromatic light is incident on a diamond at an angle of  $49.0^\circ$ .

The refractive index of diamond for this light is 2.42.

Calculate the angle of refraction  $\theta$ .

3

- (b) Calculate the critical angle of the diamond for this light.

3

- (c) Moissanite is a transparent material with a greater refractive index than diamond. A sample of moissanite is made into the same shape as the diamond.

State whether the sample of moissanite sparkles more or less than the diamond.

You must justify your answer.

3